

# CATALOGUE NOW ON-LINE

For the latest version of this catalogue go to our website at [www.thewoodworks.com.au](http://www.thewoodworks.com.au)  
Click on the Home Page link to the school catalogue.

## SCOPE OF THIS CATALOGUE

We sell in excess of 8,000 products. This catalogue lists a smaller selection of items which have proven popular with schools over many years. For other items please contact us or search our website at [www.thewoodworks.com.au](http://www.thewoodworks.com.au).

## ACCOUNTS

We offer immediate terms to any Australian school. No account opening procedures are needed.  
All we ask is that orders are on official school letterhead and have an Order Number

## FIXED WRITTEN QUOTES

To speed up your admin time we can supply you with a written quote for any of our items.

## HEGNER MACHINES - SALES & SERVICE

We are very proud of the service record of our Hegner machines many of which are still performing as new after 25 years in Australian schools. We can use a metropolitan or national courier service to ship machines back to us for evaluation if you wish. We will provide a repair quote and advise the current replacement cost of the machine to assist with your repair decision.

We offer service in-situ in schools in most of suburban Sydney. Alternatively we sell Hegner spare parts for schools who wish to carry out their own servicing.

If you need machines evaluated for repair or wish to arrange service use the hotline below.

**FOR SERVICE CALL (02) 9979 7797**

### INDEX

Index	1	Pen making	17
Scroll Saws & Accessories	2	Pepper Mill making	18
Scroll saw blades	4	Toy Wheel Cutters	18
ZFG Comb Jointer	6	Clock making	19
Joint Genie Doweling	7	Consumables & Finishes	21
Vacuums	7	Putty Bricks	22
Plastics Strip Heaters	8	Shellac	22
Sanding machines	8	Abrasive Backing Pads & Discs	23
Bench Plane Spares	9	Disc Cement	24
Turning Tools	10	Carving	25
Sharpening	11	Hand Tools	25
Pyrography	13	Drill & Borers	29
Pinewood and Plywood	13	Bench Vices	30
Project hardware	14	Repackaging	32
CD & DVD Racks	17		

**For complete data sheets and more information on all products in this catalogue search using the ITEM CODE in the SEARCH box on the HOME PAGE at [www.thewoodworks.com.au](http://www.thewoodworks.com.au)**

## SCROLL SAWING

Note: There are 7 models of Hegner scroll saw available. Please search our site for those not detailed below

### SCROLL SAWS - HEGNER - GERMANY

The Multicut 1 is our best selling quality scroll saw with an excellent service record and with thousands in use in Australian schools. A quality scroll saw is undoubtedly the safest powered wood saw available for use in schools. Statistically the very small risk profile of scroll saws suggests eye injury from broken blade parts and being hurt by machines falling off benches exceed the minimal risk of being cut by the blade. Hegner scroll saws can be bolted to the bench and the patented blade retaining system greatly minimises risk from blade fragments. Despite this we still suggest eye protection must be worn at all times.

The Multicut 1 is available in either single or variable speed models. Blade guards and work hold down arms are now standard for all school orders.

Variable speed is factory fitted and must be specified at order time. Note that Hegner scroll saws use pinless blades of which there are numerous patterns and sizes to enable working with the widest variety of materials.

Other scroll saw make use pinned blades which are more expensive, available in only 3 or 4 patterns and may be limited to wood.

The patented Hegner blade clamp arrangement contains broken blades and minimises risks from pieces of blade being thrown about.

These machines are fully supported with spare parts and maintenance across Australia. We routinely service machines more than 25 years old which are still in excellent functioning condition.

**Hegner Multicut 1**



**Hegner Multicut 2S**



- ✓ Saw, Scroll, Multicut 1, single speed
- ✓ Saw, Scroll, Multicut 1, vari speed
- ✓ Saw, Scroll, Multicut-2S, single speed
- ✓ Saw, Scroll, Multicut-2S, vari speed
- ✓ Saw, Scroll, Multicut-SE, vari speed

ITEM	RRP	Ex GST
<b>M0239</b>	<b>995.00</b>	<b>904.55</b>
<b>M0240</b>	<b>1,395.00</b>	<b>1,268.18</b>
<b>M0241</b>	<b>1,590.00</b>	<b>1,445.45</b>
<b>M0242</b>	<b>1,995.00</b>	<b>1,813.64</b>
<b>M0243</b>	<b>2,395.00</b>	<b>2,177.27</b>

### POPULAR SPARES, ACCESSORIES & UPGRADES

- ✓ Assembly, Tension Rod with Quick Release function
- ✓ Assembly, Joint hose, for M1
- ✓ Assembly, Joint hose, for M2S / SE / Quick
- ✓ Bracket, Retaining, for Dust Trumpet
- ✓ Arm, Hold Down for Multicut 1 - WITHOUT GUARD
- ✓ Arm, Hold Down for Multicut 2S - WITHOUT GUARD
- ✓ Arm, Hold Down for Multicut 1 - WITH BLADE GUARD
- ✓ Arm, Hold Down for Multicut 2S - WITH BLADE GUARD
- ✓ Guard, Blade, for use with Multicut Hold Down Arm
- ✓ Part, Multicut 1, #023, Clamp, Blade
- ✓ Clamp, Quick Release, for Inside Sawing
- ✓ Key, Blade Fitting, for Hegner Blade Clamps
- ✓ Switch, Foot, for M1 / M2 / SE / Quick
- ✓ Lamp, Machine, for Multicut 1 (Screw cap lampholder)
- ✓ Bracket, for Work Lamp, for M1 C Frame
- ✓ Bracket, for Work Lamp, for M2S, SE & Quick C Frame

<b>S1001A</b>	<b>99.00</b>	<b>90.00</b>
<b>S6914</b>	<b>73.27</b>	<b>66.61</b>
<b>S6916</b>	<b>77.31</b>	<b>70.28</b>
<b>S6905A</b>	<b>22.50</b>	<b>20.45</b>
<b>A7050</b>	<b>121.00</b>	<b>110.00</b>
<b>A7051</b>	<b>121.00</b>	<b>110.00</b>
<b>A7060</b>	<b>132.95</b>	<b>120.86</b>
<b>A7061</b>	<b>132.95</b>	<b>120.86</b>
<b>A7040</b>	<b>34.95</b>	<b>31.77</b>
<b>S1014</b>	<b>19.95</b>	<b>18.14</b>
<b>S6845</b>	<b>52.73</b>	<b>47.94</b>
<b>S0977</b>	<b>17.95</b>	<b>16.32</b>
<b>A7070</b>	<b>149.95</b>	<b>136.32</b>
<b>A7072</b>	<b>69.95</b>	<b>63.59</b>
<b>A7074</b>	<b>28.75</b>	<b>26.14</b>
<b>A7075</b>	<b>28.75</b>	<b>26.14</b>

- Introduces quick release function
- Improved dust collection
- Improved dust collection
- Protects dust trumpet from damage
- Holds work on table while cutting
- Holds work on table while cutting
- Supports guard & holds work on table
- Supports guard & holds work on table
- Guard - screws onto hold down arm
- Spare standard blade clamp
- Assists with pierced work
- Spare tightening key
- Allows hands free stop start
- Improves work station lighting
- Factory made bracket for machine
- Factory made bracket for machine

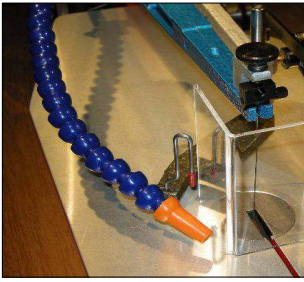
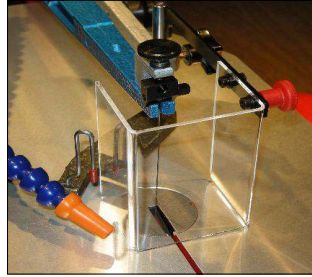
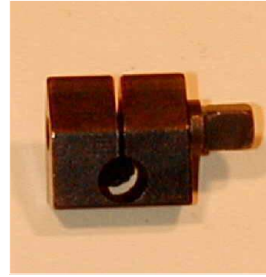
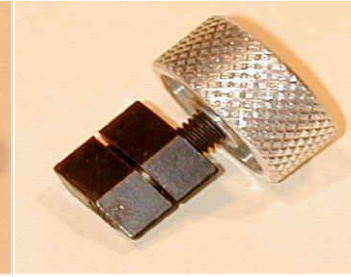
**S6914 & S6916 Joint hose****A7040 Blade guard****S1014****S6845****S0977****A7070****A7072****A7074 & S1001A****MULTICUT SPECIFICATIONS****Models 1 and 1e**

Shipping Weight	20 kg
Machine weight	16 kg
Warranty	3 years
Length	520mm (20 inches)
Width	270mm (11 inches)
Throat	365mm (14 inches)
Max Cut	50mm (2 inches)
Blades	Pinless 130 mm (5 inch)
Table	Machined alloy
Table size	435mm x 230mm (17" x 9")
Table tilt	0~45 degrees
Quick Tension Release	Yes at Rear
Quick Blade Clamp	No (accessory)
Indicative Noise At Idle	64.1 dB(A)
Indicative Noise Machining	74.5 dB(A)
Dust management	Dual - bellows blower & vacuum port
Stroke	Two options - 12 & 18mm
Ex Factory Stroke Setting	18mm
Speed Fixed (Model 1)	1400 spm
Speed Variable (Model 1e)	400~1400 spm
Motor	100Watts (230v, 50Hz, AC)
Motor Type (Model 1)	TEFC Cap start continuous duty
Motor Type (Model 1e)	TEFC VS drive continuous duty
Motor rating	Continuous
Indicative Capacities	
Soft Wood	50mm
Hard Wood	40mm
Alloy, Copper, Brass	5mm
Hard plastics, perspex	15mm
Polyurethane foam	50mm

**Models 2S and 2Se**

Shipping Weight	22 kg
Machine Weight	19kg
Warranty	3 years
Length	610mm (24 inches)
Width	280mm (11 inches)
Throat	460mm (18 inches)
Max Cut	65mm (2 1/2 inches)
Blades	Pinless 130 mm (5 inch)
Table 2S & 2Se	Machined alloy
Table size	435mm x 230mm (17" x 9")
Table tilt	-12 ~ +45 degrees
Quick Arm Tension Release	Yes at Front
Quick Blade Clamp	Yes
Indicative Noise At Idle	64.1 dB(A)
Indicative Noise Machining	74.5 dB(A)
Dust management	Dual - bellows blower & vacuum
Stroke	Two options - 12 & 19mm
Ex Factory Stroke Setting	19mm
Speed Fixed (Model 2S)	1400 spm
Speed variable (Model 2Se)	400~1400 spm
Motor	100Watts (230v, 50Hz, AC)
Motor Type (Model 2S)	TEFC Cap start contin. duty
Motor Type (Model 2Se)	TEFC VS drive contin. duty
Motor rating	Continuous
Indicative Capacities	
Soft Wood	65mm
Hard Wood	50mm
Alloy, Copper	5mm
Brass, Silver	10mm
Iron soft steel	8mm
Hard plastics, perspex	15mm
Polyurethane foam	65mm

**BLADES - FOR SCROLL AND COPING SAWS**

**GENERAL PURPOSE (Note: 1 gross = 12 dozen)**

General purpose blade for wood, plastics etc.

	ITEM	RRP	Ex GST
✓ Pebeco Pinless, 1doz, #3, PEBECO, #180	L1404	11.90	10.82
✓ Pebeco Pinless, 1doz, #5, PEBECO, #180	L1406	11.90	10.82
✓ Pebeco Pinless, 1doz, #7, PEBECO, #180	L1408	11.62	10.56
✓ Pebeco Pinless, 1doz, #9, PEBECO, #180	L1410	12.64	11.50
✓ Pebeco Pinless, 1doz, #14, PEBECO, #180	L1413	13.25	12.05
✓ Pebeco Pinless, 1gross, #3, PEBECO, #180	L1433	95.35	86.68
✓ Pebeco Pinless, 1gross, #5, PEBECO, #180	L1435	95.35	86.68
✓ Pebeco Pinless, 1gross, #7, PEBECO, #180	L1437	98.40	89.45
✓ Pebeco Pinless, 1gross, #9, PEBECO, #180	L1439	98.40	89.45
✓ Pebeco Pinless, 1gross, #14, PEBECO, #180	L1442	109.15	99.23

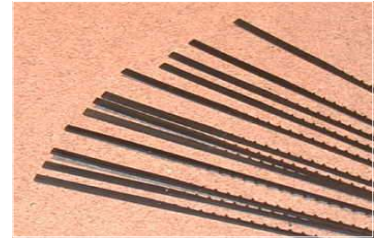

**ULTRA SMOOTH CUT - HAVE SOME UNDERSIDE UPWARD FACING TEETH (Note: 1 gross = 12 dozen)**

Fix/reverse blades have some upward cutting teeth to minimise tearout on the bottom of the work

✓ Fix/Reverse Pinless, 1 doz, #1	L1371	11.90	10.82
✓ Fix/Reverse Pinless, 1doz, #5,	L1373	11.62	10.56
✓ Fix/Reverse Pinless, 1doz, #7,	L1374	12.64	11.50
✓ Fix/Reverse Pinless, 1doz, #9,	L1375	13.25	12.05
✓ Fix/Reverse Pinless, 1doz, #12,	L1376	13.25	12.05
✓ Fix/Reverse Pinless, 1gross, #1,	L1391	88.15	80.14
✓ Fix/Reverse Pinless, 1gross, #5,	L1393	96.15	87.41
✓ Fix/Reverse Pinless, 1gross, #7,	L1394	97.12	88.29
✓ Fix/Reverse Pinless, 1gross, #9,	L1395	106.37	96.70
✓ Fix/Reverse Pinless, 1gross, #12,	L1396	116.12	105.56



**TWISTER BLADES - CUT IN ALL DIRECTIONS (Note: 1 gross = 12 dozen)**

Twister blades have spirally teeth which allows cuts in any direction without rotating the work

✓ Blades, Scroll Saw, Pinless, 1doz, #1, TWISTER	L1445	14.52	13.20
✓ Blades, Scroll Saw, Pinless, 1doz, #3, TWISTER	L1446	14.52	13.20
✓ Blades, Scroll Saw, Pinless, 1doz, #5, TWISTER	L1447	14.52	13.20
✓ Blades, Scroll Saw, Pinless, 1 Gross, #1, TWISTER	L1450	109.94	99.95
✓ Blades, Scroll Saw, Pinless, 1 Gross, #3, TWISTER	L1451	111.13	101.03
✓ Blades, Scroll Saw, Pinless, 1 Gross, #5, TWISTER	L1452	113.66	103.33

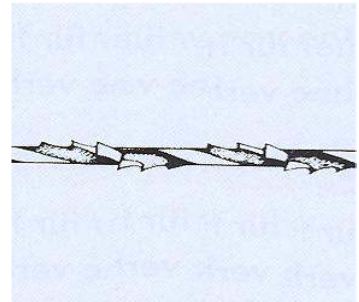

**METAL CUTTING - FOR SOFT METALS (Note: 1 gross = 12 dozen)**

✓ Blades, Scroll Saw, Pinless, 1 doz, #1 ANTILOPE BLUE	L1535	15.83	14.39
✓ Blades, Scroll Saw, Pinless, 1 doz, #3 ANTILOPE BLUE	L1536	15.74	14.31
✓ Blades, Scroll Saw, Pinless, 1 doz, #5 ANTILOPE BLUE	L1537	17.32	15.75
✓ Blades, Scroll Saw, Pinless, 1 doz, #7 ANTILOPE BLUE	L1538	21.62	19.65
✓ Blades, Scroll Saw, Pinless, 1 doz, #9 ANTILOPE BLUE	L1539	25.92	23.56
✓ Blades, Scroll Saw, Pinless, 1 gross, #1 ANTILOPE BLUE	L1550	146.12	132.84
✓ Blades, Scroll Saw, Pinless, 1 gross, #3 ANTILOPE BLUE	L1551	145.26	132.05
✓ Blades, Scroll Saw, Pinless, 1 gross, #5 ANTILOPE BLUE	L1552	159.91	145.38
✓ Blades, Scroll Saw, Pinless, 1 gross, #7 ANTILOPE BLUE	L1553	199.57	181.43
✓ Blades, Scroll Saw, Pinless, 1 gross, #9 ANTILOPE BLUE	L1554	239.22	217.48

**PINNED BLADES FOR OTHER MACHINES (Note: 1 gross = 12 dozen)**

✓ Blades, Scroll Saw, Pinned, 130mm 10 tpi, pkt of dozen,	L1660	14.78	13.44
✓ Blades, Scroll Saw, Pinned, 130mm 15 tpi, pkt of dozen,	L1661	14.78	13.44
✓ Blades, Scroll Saw, Pinned, 130mm 20 tpi, pkt of dozen	L1662	14.78	13.44
✓ Blades, Scroll Saw, Pinned, 130mm 25 tpi, pkt of dozen	L1663	14.78	13.44
✓ Blades, Scroll Saw, Pinned, 130mm 10 tpi, 1 Gross	L1670	177.41	161.29
✓ Blades, Scroll Saw, Pinned, 130mm 15 tpi, 1 Gross	L1671	177.41	161.29
✓ Blades, Scroll Saw, Pinned, 130mm 20 tpi, 1 Gross	L1672	177.41	161.29
✓ Blades, Scroll Saw, Pinned, 130mm 25 tpi, 1 Gross	L1673	177.41	161.29

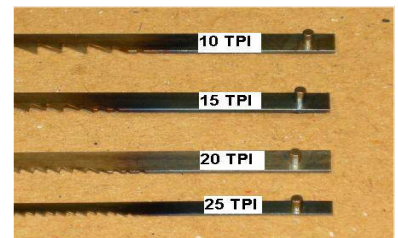

**BLADE DIMENSIONS**

ITEM	COUNT	SIZE	Pins	LONG	REV. TEETH	KERF	WIDTH	TPI	PITCH mm
<b>PEBECO 180</b>									
L1400	1 x doz	#2/0	no	130mm		0.25	0.58	30	0.85
L1404	1 x doz	#3	no	130mm		0.34	0.77	20	1.27
L1406	1 x doz	#5	no	130mm		0.39	1.03	17	1.54
L1408	1 x doz	#7	no	130mm		0.44	1.20	14	1.81
L1410	1 x doz	#9	no	130mm		0.48	1.50	14	1.81
L1413	1 x doz	#14	no	130mm		0.55	1.90	10	2.54
L1429	12 x doz	#2/0	no	130mm		0.25	0.58	30	0.85
L1433	12 x doz	#3	no	130mm		0.34	0.77	20	1.27
L1435	12 x doz	#5	no	130mm		0.39	1.03	17	1.54
L1437	12 x doz	#7	no	130mm		0.44	1.20	14	1.81
L1439	12 x doz	#9	no	130mm		0.48	1.50	14	1.81
L1442	12 x doz	#14	no	130mm		0.55	1.90	10	2.54
<b>FIX / REVERSE 400/R</b>									
L1371	1 x doz	#1	no	130mm	8	0.30	0.77	15	1.69
L1373	1 x doz	#5	no	130mm	8	0.38	0.93	12	2.12
L1374	1 x doz	#7	no	130mm	8	0.42	1.10	12	2.12
L1375	1 x doz	#9	no	130mm	8	0.46	1.35	12	2.12
L1376	1 x doz	#12	no	130mm	4	0.52	1.70	8	3.18
L1391	12 x doz	#1	no	130mm	8	0.30	0.77	15	1.69
L1393	12 x doz	#5	no	130mm	8	0.38	0.93	12	2.12
L1394	12 x doz	#7	no	130mm	8	0.42	1.10	12	2.12
L1395	12 x doz	#9	no	130mm	8	0.46	1.35	12	2.12
L1396	12 x doz	#12	no	130mm	4	0.52	1.70	8	3.18
<b>TWISTER</b>									
L1445	1 x doz	#1	no	130mm	7	0.72	0.70		
L1446	1 x doz	#3	no	130mm	7	0.85	0.77		
L1447	1 x doz	#5	no	130mm	7	0.88	0.90		
L1450	12 x doz	#1	no	130mm	7	0.72	0.70		
L1451	12 x doz	#3	no	130mm	7	0.85	0.77		
L1452	12 x doz	#5	no	130mm	7	0.88	0.90		
<b>METAL CUTTING</b>									
L1535	1 x doz	#1	no	130mm		0.28	0.62	51	0.50
L1536	1 x doz	#3	no	130mm		0.36	0.75	41	0.63
L1537	1 x doz	#5	no	130mm		0.40	0.85	33	0.77
L1538	1 x doz	#7	no	130mm		0.50	1.10	28	0.91
L1539	1 x doz	#9	no	130mm		0.55	1.30	23	1.11
L1550	12 x doz	#1	no	130mm		0.28	0.62	51	0.50
L1551	12 x doz	#3	no	130mm		0.36	0.75	41	0.63
L1552	12 x doz	#5	no	130mm		0.40	0.85	33	0.77
L1553	12 x doz	#7	no	130mm		0.50	1.10	28	0.91
L1554	12 x doz	#9	no	130mm		0.55	1.30	23	1.11
<b>PINNED SCROLLSAW BLADES</b>									
L1660	1 x doz	10	yes	130mm		0.50	3.00	10	2.54
L1661	1 x doz	15	yes	130mm		0.50	3.00	15	1.69
L1662	1 x doz	20	yes	130mm		0.50	3.00	20	1.27
L1663	1 x doz	25	yes	130mm		0.25	2.00	25	1.02
L1670	12 x doz	10	yes	130mm		0.50	3.00	10	2.54
L1671	12 x doz	15	yes	130mm		0.50	3.00	15	1.69
L1672	12 x doz	20	yes	130mm		0.50	3.00	20	1.27
L1673	12 x doz	25	yes	130mm		0.25	2.00	25	1.02
<b>PINNED COPING SAW</b>									
L1891	1 x doz		yes	165mm		0.50		15	1.69
L1892	12 x doz		yes	165mm		0.50		15	1.69
L1893	1 x doz		yes	165mm		0.50		20	1.27
L1894	12 x doz		yes	165mm		0.50		20	1.27

## DECORATIVE JOINTING

The ZFG is a simple, safe machine with excellent dust/chip extraction which offers students the capability of making perfect finger joints. We have a number of school customers making serving trays, lidded boxes and pencil boxes made with the ZFG for middle and senior secondary years. The ZFG has a fully guarded cutter and has proven a safer option than the use of hand held routers on dovetail jigs. Now with improved, more powerful router motor.



Helically ground cutters for ZFG



### FINGER JOINTER - HEGNER - GERMANY

- ✓ Finger Jointer, ZFG Comb/Finger Jointing Machine

ITEM	RRP	Ex GST
<b>M0478</b>	<b>1,195.00</b>	<b>1,086.36</b>

### CUTTERS

The machine is supplied with either 8mm or 6.35 (1/4 inch) shank helically ground special router cutters in 4mm, 6mm, 8mm and 10mm diameters. The 8mm shank cutters are preferred as they are more robust. There is also a 12mm diameter cutter available

- ✓ Bit, Router, 4mm, 6.35mm Shank, ZFG Comb Jointer
- ✓ Bit, Router, 6mm, 6.35mm Shank, ZFG Comb Jointer
- ✓ Bit, Router, 8mm, 6.35mm Shank, ZFG Comb Jointer
- ✓ Bit, Router, 10mm, 6.35mm Shank, ZFG Comb Jointer
- ✓ Bit, Router, 12mm, 6.35mm Shank, ZFG Comb Jointer
  
- ✓ Bit, Router, 4mm, 8mm Shank, ZFG Comb Jointer
- ✓ Bit, Router, 6mm, 8mm Shank, ZFG Comb Jointer
- ✓ Bit, Router, 8mm, 8mm Shank, ZFG Comb Jointer
- ✓ Bit, Router, 10mm, 8mm Shank, ZFG Comb Jointer
- ✓ Bit, Router, 12mm, 8mm Shank, ZFG Comb Jointer

ITEM	RRP	Ex GST
<b>R6202</b>	<b>47.67</b>	<b>43.33</b>
<b>R6203</b>	<b>47.67</b>	<b>43.33</b>
<b>R6204</b>	<b>47.67</b>	<b>43.33</b>
<b>R6205</b>	<b>47.67</b>	<b>43.33</b>
<b>R6206</b>	<b>47.67</b>	<b>43.33</b>
<b>R6210</b>	<b>47.67</b>	<b>43.33</b>
<b>R6211</b>	<b>47.67</b>	<b>43.33</b>
<b>R6212</b>	<b>47.67</b>	<b>43.33</b>
<b>R6213</b>	<b>47.67</b>	<b>43.33</b>
<b>R6214</b>	<b>47.67</b>	<b>43.33</b>



**JOINT GENIE DOWELING JIGS - BRITISH MADE**

Doweling remains one of the simplest and strongest methods of joining wood and one of the safest for schools.

Given a quality adhesive and hardwood dowels, Joint Genie jigs allow the simple joining of sheet and post & rail structures for a wide variety of school woodworking. Doweling requires the use of much safer power or hand drills than equivalent methods using hand held routers.

See our site for a link to a demonstration DVD. Contact us for dowel purchase options

**Craftsman 8mm**



**Professional 6mm or 8mm or 10mm**



**Multi Professional 6/8/10mm**



**Jobber 6mm or 8mm**



- ✓ 'Joint Genie', Craftsmen, 8mm
- ✓ 'Joint Genie', Professional, 6mm
- ✓ 'Joint Genie', Professional, 8mm
- ✓ 'Joint Genie', Professional, 10mm
- ✓ 'Joint Genie', Multi Professional, 6mm, 8mm, 10mm
- ✓ 'Joint Genie', Jobber, 6mm
- ✓ 'Joint Genie', Jobber, 8mm

ITEM	RRP	Ex GST
E0136	265.91	241.74
E0143	152.19	138.35
E0144	158.62	144.20
E0145	158.62	144.20
E0151	300.19	272.90
E0155	116.30	105.73
E0156	116.30	105.73

**VACUUMS**

**HEGNER MAXIMUS UNDERBENCH VACUUM**

The Hegner Maximus is the perfect machine for installations where distributed dust control is installed.

The Maximus from Hegner is a down-size, quiet vacuum with variable suction which is ideally suited to placement under work benches. It has a master-slave feature which allows bench top machines to automatically switch the vacuum on and off.

This saves on power consumption and reduces noise in the work room. Only 62dB (A) at max power

- ✓ Vacuum/Dust Extractor, Maximus 13E
- ✓ Bag, Filter, for Hegner Maximus 13E, 10 pieces

ITEM	RRP	Ex GST
M0920	589.55	535.95
C0720	72.19	65.63

**Specifications**

Model	Hegner Maximus 13E
Height	405mm
Width	290mm
Depth	400mm
Weight	tba
Mains	230 volt AC, 50 Hz
Max power	1250 watts
Noise at Max power	62dB(A)
Variable suction & noise	Yes
Dust volume	13 litres
Mains cable	10 metres
Dust hose	2.5 metres
Hose swivel connection	Yes
Suction throughput	Max. 60 litres/sec
Vacuum Pressure	290 mbar
Filtration	HEPA H21
Bags	Yes, disposable (See C0720)
Accessories	Floor wand, Crevice & Furniture Brush Upholstery nozzles



**STRIP HEATERS FOR PLASTICS WORK**

- ✓ 500mm Capacity, 240Volts, 200Watts, #SH 500-1
- ✓ 1000mm Capacity, 240Volts, 200Watts, #SH 1000-1

<b>M0050</b>	<b>714.00</b>	<b>649.09</b>
<b>M0051</b>	<b>891.00</b>	<b>810.00</b>

**MODEL 500  
MODEL 1000**



**SANDING**

**HEGNER SANDERS**

The WSM German made Hegner disc sander has a 300mm, fully guarded velcro equipped hook disc & is equipped with no-volt starting. It is fitted with an efficient dust collection port.

The HSM-300S has a tilting disc and fixed table which allows heavier pieces to be work. Digital tilt gauge is an option.

The TWS 230 table drum sander has a sanding width of 230mm and table 520mm x 320mm. Fence is optional. The TWS is the perfect companion machine for the Hegner scroll saws and finger jointers. With a fence fitted (please order as accessory) and table height perfectly adjusted it can final sand most scroll saw and box projects very safely.

The TBS 500 belt sander tilts so that the sanding platten can be either horizontal or vertical. The optional bobbin attachment fits to the belt sander. The machine has no-volt starting and excellent dust porting. (Stand illustrated but not supplied)

- ✓ Sander, Disc, 300mm, #WSM-300
- ✓ Sander, Disc, #HSM-300
- ✓ Sander, Disc, #HSM-300 S
- ✓ Sander, Drum, Hegner, #TWS230
- ✓ Sander, Drum, Belt, #TBS-500
- ✓ Sander, Bobbin, Accessory for, #TBS-500

ITEM	RRP	Ex GST
<b>M1052</b>	<b>1,165.00</b>	<b>1,059.09</b>
<b>M1051</b>	<b>1,799.00</b>	<b>1,635.45</b>
<b>M1050</b>	<b>2,038.00</b>	<b>1,852.73</b>
<b>M1094</b>	<b>665.00</b>	<b>604.55</b>
<b>M1043</b>	<b>2,995.00</b>	<b>2,722.73</b>
<b>A4131</b>	<b>372.00</b>	<b>338.18</b>

**M1052**



**M1094**

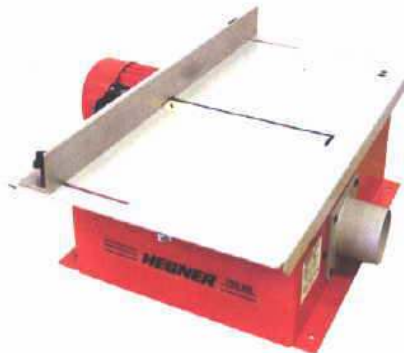

**M1050**



**M1043**



**A4131**



**M1051**

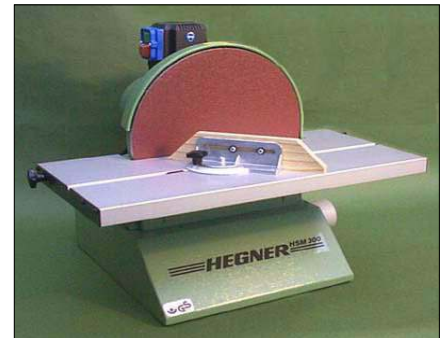

## BENCH PLANE SPARE PARTS

For several years spares for Stanley planes for been only intermittently available and in many cases only in quite extensive kits. In addition to these kits we now can offer some parts to the component level for all other than Y levers, lateral adjust levers and frog clips all of which require the purchase of a full frog assembly.

### Spares

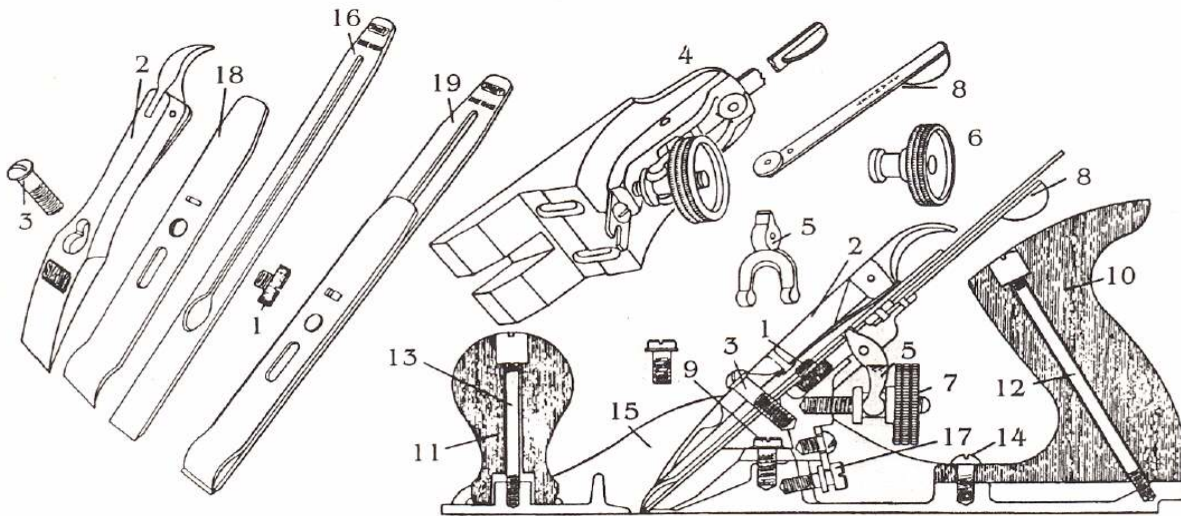

1	Cap screw	6	Adjusting nut	11	Knob	16	Cutting iron
2	Lever cap	7	Adjusting nut screw	12	Handle bolt & nut	17	Frog adjusting screw
3	Lever cap screw	8	Lateral adjusting screw	13	Knob bolt & nut	18	Back iron
4	Frog complete	9	Frog screw	14	Handle screw		
5	"Y" adjusting lever	10	Handle	15	Plan body		

#### SPARES KITS

	ITEM	RRP	Ex GST	PART
✓ No: 1, Handle & Knob, for #3, #4	S2980	25.64	23.31	10,12,14,11,13
✓ No: 2, Handle & Knob, for #4 1/2, #5, #5 1/2, #6, #7	S2981	25.98	23.62	10,12,14,11,13
✓ No: 3, Bench Plane Fasteners	S2983	32.54	29.58	Set of Stanley & Metric.
✓ No: 5, Frog Kit for #4, #5	S2984	83.18	75.62	4
✓ No: 8, Lever Cap for #4, #5	S2987	41.50	37.73	2
✓ No: 9, Lever Cap for #4 1/2, #5 1/2, #8, #7	S2988	68.30	62.09	2
✓ No: 12-322, Back Iron & Blade Assembly, for #3	S2989	33.28	30.25	1,16,18
✓ No: 12-323, Back Iron & Blade Assembly, for #4, #5	S2990	33.80	30.73	1,16,18
✓ No: 12-325, Back Iron & Blade Ass, for #4 1/2, 5 1/2,6,7	S2991	35.88	32.62	1,16,18

#### SPARES INDIVIDUALLY - (NOTE: ALL STANLEY THREAD, VERY NEW PLANES MAY BE METRIC)

✓ Screw & Nut, Handle, #3 to #4, #P78987	S3005	6.50	5.91	12
✓ Screw & Nut, Handle, #4.5 to #7, #P78995	S3006	6.50	5.91	12
✓ Screw & Nut, Knob, #3 & #4, #P79026	S3007	6.50	5.91	13
✓ Screw & Nut, Knob, #4.5 to #7, #P79034	S3008	6.50	5.91	13
✓ Screw, Toe, #P36396	S3010	8.12	7.38	14
✓ Screw, Frog Mounting, and Washer, #P78979	S3011	4.00	3.64	9
✓ Screw, Lever Cap, #P33066	S3012	6.50	5.91	3
✓ Screw, Cap/Back Iron, #3 to #7, #P33009	S3013	6.00	5.45	1
✓ Screw, Frog Adjusting, #P32864	S3014	6.50	5.91	17
✓ Nut, Adjusting, #P34419	S3016	12.50	11.36	6
✓ Screw, Adjusting Nut, #P34427	S3017	6.00	5.45	7
✓ Cap, Lever, #4 & #5, #P73948	S2987	41.50	37.73	2
✓ Cap, Lever, #4.5 to #7, #P73964	S2988	68.30	62.09	2
✓ Back Iron, with screw, 45mm, #3, #P12002	S2989	33.28	30.25	18
✓ Back Iron, with screw, 50mm, #4, #5, #P12003	S2990	33.80	30.73	18
✓ Back Iron & screw, 60mm, #4 1/2, 5 1/2, 6, 7, #P12004	S2991	35.88	32.62	18

## P&N HIGH SPEED STEEL WOODTURNING TOOLS - P&N - AUSTRALIA

P&N tools are fabricated in Australia using Austrian high speed steel. They have many features which make them an excellent choice for school use. They are fitted with very tough Spotted Gum handles and the gouge flutes are ground extra long for extended tool life. The skews have a fully rounded bottom edge - the 24mm skew is 8mm thick, not the usual 6mm.

Note: We supply round nose scrapers for the price of square scrapers for no extra charge

### P&N SPINDLE (conventional flute)

	ITEM	RRP	Ex GST
✓ Spindle Gouge, 6mm, Handled,	T6300	60.18	54.71
✓ Spindle Gouge, 6mm, Un Handled	T6301	37.02	33.65
✓ Spindle Gouge, 8mm, Handled	T6302	62.10	56.45
✓ Spindle Gouge, 8mm, Un Handled	T6303	42.79	38.90
✓ Spindle Gouge, 10mm, Handled	T6304	75.34	68.49
✓ Spindle Gouge, 10mm, Un Handled	T6305	47.82	43.47
✓ Spindle Gouge, 12mm, Handled	T6306	78.54	71.40
✓ Spindle Gouge, 12mm, Un Handled	T6307	58.56	53.24
✓ Spindle Gouge, 16mm, Handled	T6308	98.60	89.64
✓ Spindle Gouge, 16mm, Un Handled	T6309	73.62	66.92
✓ Spindle Gouge, 19mm, Handled	T6310	108.92	99.02
✓ Spindle Gouge, 19mm, Un Handled	T6311	90.26	82.06

T6300 - T6311

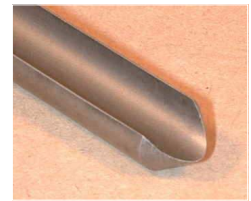

### P&N BOWL GOUGE (measured by bar diameter)

	ITEM	RRP	Ex GST
✓ Bowl Gouge, 6mm, Handled	T6315	61.73	56.12
✓ Bowl Gouge, 6mm, Un Handled	T6316	40.38	36.71
✓ Bowl Gouge, 8mm, Handled	T6317	64.87	58.97
✓ Bowl Gouge, 8mm, Un Handled	T6318	44.09	40.08
✓ Bowl Gouge, 10mm, Handled	T6319	77.86	70.78
✓ Bowl Gouge, 10mm, Un Handled	T6320	51.16	46.51
✓ Bowl Gouge, 12mm, Handled	T6321	82.20	74.72
✓ Bowl Gouge, 12mm, Un Handled	T6322	62.36	56.69
✓ Bowl Gouge, 16mm, Handled	T6323	96.10	87.36
✓ Bowl Gouge, 16mm, Un Handled	T6324	74.84	68.04

T6315 - T6324



### P&N SUPA GOUGE (extra length flute - long & strong)

✓ Supa Gouge, 16mm, Handled	T6330	133.70	121.55
✓ Supa Gouge, 16mm, Un Handled	T6331	114.92	104.47
✓ Supa Gouge, 22mm, Handled	T6332	159.30	144.82
✓ Supa Gouge, 22mm, Un Handled	T6333	140.54	127.77

T6330 - T6333



### P&N DETAIL GOUGE (shallow flute high waisted)

✓ Detail Gouge, 8mm, Handled	T6338	85.26	77.51
✓ Detail Gouge, 8mm, Un Handled	T6339	66.49	60.45
✓ Detail Gouge, 10mm, Handled	T6340	88.93	80.85
✓ Detail Gouge, 10mm, Un Handled	T6341	70.23	63.85
✓ Detail Gouge, 12mm, Handled	T6342	93.95	85.41
✓ Detail Gouge, 12mm, Un Handled	T6343	75.29	68.45
✓ Detail Gouge, 16mm, Handled	T6344	110.51	100.47
✓ Detail Gouge, 16mm, Un Handled	T6345	97.38	88.52

T6338 - T6345



### P&N ROUGHING GOUGE (25 & 32 ground bar, 40mm forged)

✓ 25mm Roughing Gouge, Handled	T6350	155.86	141.69
✓ 25mm Roughing Gouge, Un Handled	T6351	137.21	124.74
✓ 32mm Roughing Gouge, Handled	T6352	202.54	184.13
✓ 32mm Roughing Gouge, Un Handled	T6353	183.68	166.98

T6350 - T6353



### P&N SKEW

- ✓ Standard Skew, 12 x 6mm, Handled
- ✓ Standard Skew, 12 x 6mm, Un Handled
- ✓ Standard Skew, 18 x 6mm, Handled
- ✓ Standard Skew, 18 x 6mm, Un Handled
- ✓ Standard Skew, 24mm x 8mm, Handled
- ✓ Standard Skew, 24mm x 8mm, Un Handled
- ✓ Standard Skew, 30 x 8mm, Handled
- ✓ Standard Skew, 30 x 8mm, Un Handled

<b>T6360</b>	<b>97.50</b>	<b>88.63</b>
<b>T6361</b>	<b>59.36</b>	<b>53.97</b>
<b>T6362</b>	<b>118.81</b>	<b>108.01</b>
<b>T6363</b>	<b>79.85</b>	<b>72.59</b>
<b>T6364</b>	<b>136.48</b>	<b>124.07</b>
<b>T6365</b>	<b>88.93</b>	<b>80.85</b>
<b>T6366</b>	<b>148.66</b>	<b>135.15</b>
<b>T6367</b>	<b>104.35</b>	<b>94.87</b>

**T6360 - T6367**

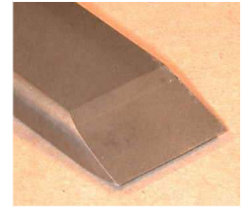

### P&N PARTING

- ✓ Standard Section Parting Tool, 3 x 12mm, Handled
- ✓ Standard Section Parting Tool, 3 x 12mm, Un Handled
- ✓ Standard Section Parting Tool, 6 x 12mm, Handled
- ✓ Standard Section Parting Tool, 6 x 12mm, Un Handled

ITEM	RRP	Ex GST
<b>T6370</b>	<b>72.56</b>	<b>65.96</b>
<b>T6371</b>	<b>53.79</b>	<b>48.90</b>
<b>T6372</b>	<b>83.22</b>	<b>75.65</b>
<b>T6373</b>	<b>61.38</b>	<b>55.80</b>

**T6370 - T6373**



### P&N SQUARE NOSE SCRAPER

- ✓ Square Nose Scraper, 12 x 8mm, Handled
- ✓ Square Nose Scraper, 12 x 8mm, Un Handled
- ✓ Square Nose Scraper, 18 x 8mm, Handled
- ✓ Square Nose Scraper, 18 x 8mm, Un Handled
- ✓ Square Nose Scraper, 24 x 8mm, Handled
- ✓ Square Nose Scraper, 24 x 8mm, Un Handled
- ✓ Square Nose Scraper, 30 x 8mm, Handled
- ✓ Square Nose Scraper, 30 x 8mm, Un Handled

<b>T6375</b>	<b>85.75</b>	<b>77.95</b>
<b>T6376</b>	<b>54.01</b>	<b>49.10</b>
<b>T6377</b>	<b>110.62</b>	<b>100.57</b>
<b>T6378</b>	<b>64.03</b>	<b>58.21</b>
<b>T6379</b>	<b>120.40</b>	<b>109.46</b>
<b>T6380</b>	<b>71.50</b>	<b>65.00</b>
<b>T6381</b>	<b>124.66</b>	<b>113.33</b>
<b>T6382</b>	<b>81.65</b>	<b>74.23</b>

**T6375 - T6382**

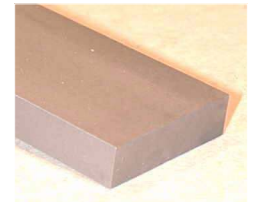

### P&N BEADING

- ✓ Beading Tool, 10 x 10mm, Handled
- ✓ Beading Tool, 10 x 10mm, Un Handled

<b>T6385</b>	<b>90.03</b>	<b>81.85</b>
<b>T6386</b>	<b>52.02</b>	<b>47.29</b>

**T6385 - T6386**

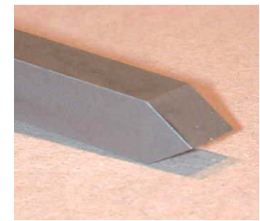

## SHARPENING

### SLOW SPEED WATER GRINDERS - SCANGRIND - DENMARK

Slow speed water grinders sharpen all carbon steel edge tools with minimal risk to the operator. Water grinders are a perfect solution for bench and carving chisels and hand plane blades. The wheel rotates slowly in a water bath making it impossible to overheat the tool. These machines are safer than high speed bench grinders and the grinding process is slower and more controllable. Item Code M0004 is supplied with a diamond honing lapping plate which allows for final honing of edges. There are accessories for assisted grinding, repeatability and additional precision - see below.

### WATER GRINDERS , ACCESSORIES & SPARES

- ✓ Grinder, Water, Scan 200EK, #SC200EK
- ✓ Unit, Base, 'Startset', for Scangrind 200, #3800025
- ✓ Guide, Sliding, for Scan Grind 200, #3800026
- ✓ Jig, Grinding, Universal, for Scan 200, #3800023
- ✓ Jig, Grinding, Fingernail, for Scan 200, #3800021
- ✓ Wheel, Grinding, Scan 200mm Water Grinder, Spare

ITEM	RRP	Ex GST
<b>M0005</b>	<b>518.70</b>	<b>471.55</b>
<b>A1981</b>	<b>104.58</b>	<b>95.07</b>
<b>A1982</b>	<b>81.90</b>	<b>74.45</b>
<b>A1983</b>	<b>78.12</b>	<b>71.02</b>
<b>A1986</b>	<b>104.58</b>	<b>95.07</b>
<b>S1341</b>	<b>164.64</b>	<b>149.67</b>



**A1981 + A1982**

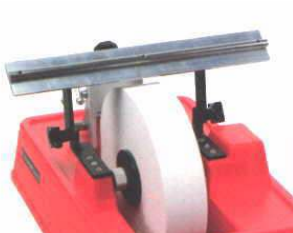

**A1981 + A1982 + A1983**



**A1986**



**S1341**



**HIGH SPEED BENCH GRINDERS**

High speed bench grinders sharpen all steel tools including high speed steel turning tools. The grinding wheels supplied with the great majority of bench grinders are suited to grinding mild steel for welding and not tool sharpening. An aluminium oxide cool running wheel should be fitted for tool sharpening. The grinder tool rests of the majority of high speed bench grinders are unsuited to tool sharpening. The McNaughton grinder rest and accessories offer great assistance with precision grinding for all straight edge tools and, in particular, gouge forms for carving and turning. A dressing stick, either a carborundum block or diamond point, is an essential tool to keep grinding wheels maintained. Our grinder is Danish made and comes with both a regular and a quality sharpening wheel.

**BENCH GRINDERS, ACCESSORIES & SPARES**

- ✓ Grinder, Bench, 200mm (8 inch), Scan
- ✓ Rest, Tool, Adjustable Grinder
- ✓ Attachment, Multi Grind
- ✓ Wheel, Alu.Oxide 46grit, 200mm x 25mm, Multi Bushed
- ✓ Wheel, Alu.Oxide 60grit, 200mm x 25mm, Multi Bushed
- ✓ Wheel, Alu.Oxide 80grit, 200mm x 25mm, Multi Bushed
- ✓ Wheel, Alu.Oxide 80grit, 150mm x 25mm, Multi Bushed
- ✓ Wheel, Alu.Oxide 120grit, 200mm x 25mm, Multi Bushed
- ✓ Stick, Dressing, Diamond, 0.5 carat
- ✓ Stick, Dressing, Silicon Carbide, 6 x 1 x 1

ITEM	RRP	Ex GST
<b>M0024</b>	<b>478.50</b>	<b>435.00</b>
<b>A2015</b>	<b>395.00</b>	<b>359.09</b>
<b>A2018</b>	<b>114.95</b>	<b>104.50</b>
<b>S0027</b>	<b>46.15</b>	<b>41.95</b>
<b>S0028</b>	<b>46.15</b>	<b>41.95</b>
<b>S0029</b>	<b>46.15</b>	<b>41.95</b>
<b>S0030</b>	<b>30.00</b>	<b>27.27</b>
<b>S0031</b>	<b>46.15</b>	<b>41.95</b>
<b>E0001</b>	<b>63.41</b>	<b>57.65</b>
<b>E0004</b>	<b>16.95</b>	<b>15.41</b>



**M0024**

**A2015**



**A2018**



**C2202 - C2206**



**E0001**



**E0004**



**HAND SHARPENING EQUIPMENT**

Diamond sharpening plates are now available in a range of grits which means they are a complete alternative to other sharpening and honing systems. They are very durable and do not cup after extended use. Waterstones offer the ultimate edge however are not as durable as other stones or diamond plates and must be used with a honing guide. Stropps should be used with honing compound. Aluminium oxide wheels are the preferred wheel for tool sharpening on a high speed bench grinder. A honing guide which holds the straight edge tool at the correct angle is strongly recommended.

- ✓ Guide, Honing

ITEM	RRP	Ex GST
<b>T0011</b>	<b>119.95</b>	<b>109.05</b>

**T0010**



## PYROGRAPHY (WOOD BURNING) - AUSTRALIA

The Australian made Ironcore has wide acceptance in the Australian School market.

	ITEM	RRP	Ex GST
✓ Kit, Pyrography, Ironcore, Pokerworker, T3/54	E0121	295.00	268.18
✓ Handle, Ironcore Pyrography Tool, Spare	S0600	66.00	60.00
✓ Tips, Ironcore Pyrograph Tool, pkt 10	S0621	16.95	15.41

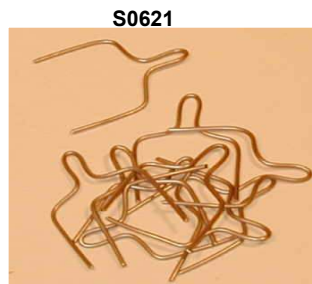

## PROJECT COMPONENTS & MATERIALS

Wood Works supplies some sizes of pre-cut plywood and pine for school projects. We supply Radiata Pine in solid wood form and Hoop Pine as plywood, both of which are fully plantation grown in Australia and are sustainably harvested. The pine is supplied fault docked which removes major knots and blemishes and is suited to many school projects. The Hoop Pine ply is a clear, pale, fine grained ply which cuts smoothly and is easily finished. It is ideal for pyrography (wood burning) projects.

Minimum orders apply. Some popular sizes are listed below. Other sizes available on request.

<b>HOOP PINE FACED PLYWOOD</b>		ITEM	RRP	Ex GST
✓ Ply, Hoop Pine, A4, 295mm x 210mm x 4mm, Packs 20		W4000	please call for quote	
✓ Ply, Hoop Pine, A4, 295mm x 210mm x 6mm, Packs 40		W4001	please call for quote	
✓ Ply, Hoop Pine, A4, 295mm x 210mm x 9mm, Packs 40		W4002	please call for quote	
✓ Ply, Hoop Pine, A4, 295mm x 210mm x 12mm, Packs 40		W4003	please call for quote	
✓ Ply, Hoop Pine, A3, 395mm x 295mm x 4mm, Packs 24		W4050	please call for quote	
✓ Ply, Hoop Pine, A3, 395mm x 295mm x 6mm, Packs 24		W4051	please call for quote	
✓ Ply, Hoop Pine, A3, 395mm x 295mm x 9mm, Packs 24		W4052	please call for quote	
✓ Ply, Hoop Pine, A3, 395mm x 295mm x 12mm, Packs 24		W4053	please call for quote	
✓ Ply, Hoop Pine, 190 x 295 x 4mm, Packs of 48		W4070	please call for quote	
✓ Ply, Hoop Pine, 295 x 295 x 4mm, Packs of 32		W4071	please call for quote	
✓ Ply, Hoop Pine, 445 x 295 x 4mm, Packs of 20		W4072	please call for quote	
✓ Ply, Hoop Pine, 445 x 310 x 4mm, Bases for Trays, Packs		W4073	please call for quote	
✓ Ply, Hoop Pine, 250mm x 140mm x 4mm, Packs of 72		W4074	please call for quote	
✓ Ply, Hoop Pine, 395mm x 395mm x 4mm, Packs of 18		W4075	please call for quote	
✓ Ply, Hoop Pine, 140mm x 140mm x 4mm, Packs of 128pcs		W4076	please call for quote	
✓ Ply, Hoop Pine, 595 x 395 x 4mm, Packs of 12		W4077	please call for quote	
✓ Ply, Hoop Pine, 140mm x 140mm x 6mm, Packs of 128pcs		W4090	please call for quote	
✓ Ply, Hoop Pine, 370mm x 295mm x 6mm, Packs of 24pcs		W4098	please call for quote	



<b>PINE WOOD, FAULT DOCKED</b>		ITEM	RRP	Ex GST
✓ 42mm x 12mm -130mm long		W5140	please call for quote	
✓ 42mm x 12mm -150mm long		W5145	please call for quote	
✓ 42mm x 12mm - 210mm long		W5151	please call for quote	
✓ 42mm x 12mm - 295mm long		W5152	please call for quote	
✓ 42mm x 12mm - 381mm long		W5153	please call for quote	
✓ 140mm x 12mm - 140mm long		W5301	please call for quote	
✓ 140mm x 12mm - 210mm long		W5302	please call for quote	
✓ 140mm x 12mm - 300mm long		W5303	please call for quote	
✓ 140mm x 12mm - 400mm long		W5304	please call for quote	
✓ 140mm x 19mm - 310mm		W5460	please call for quote	
✓ 190mm x 19mm - 200mm		W5481	please call for quote	
✓ 190mm x 19mm - 295mm A4		W5482	please call for quote	
✓ 190mm x 19mm - 350mm		W5483	please call for quote	
✓ 190mm x 19mm - 400mm		W5484	please call for quote	



We supply schools with pre cut and machined components for projects such as serving trays and bookends. Please contact us for your requirements.

## HINGES

	ITEM	RRP	Ex GST
✓ Butt, Brass, 3/4 x 5/8 inch, with 8x2.3mm screws, pair	H0200	5.25	4.77
✓ Butt, Brass, 2 1/2 x 5/8 inch, with 8x2.3mm screws, pair	H0260	13.09	11.90
✓ Butt, Brass, 90deg 1 x 5/8 inch, with 8x2.3mm screws, pair	H0261	15.12	13.75
✓ Knuckle, Brass, 5mm, pkt 6	H0400	13.95	12.68
✓ Knuckle, Brass/Nickel Plated, 5mm, pkt 6	H0401	13.95	12.68

## Hinge, Concealed Knuckle, Soss Type, Steel/Brass Plated

✓ 8mm, pair	H0449	11.00	10.00
✓ 10mm x 11mm, pair, #ZH10	H0450	9.40	8.55
✓ 12mm x 12mm, pair, #ZH12	H0451	9.60	8.73
✓ 14mm x 16mm, pair, #ZH14	H0452	9.90	9.00
✓ 16mm x 17mm, pair, #ZH16	H0453	10.40	9.45
✓ 18mm x 18mm, pair, #ZH18	H0454	13.35	12.14
✓ 24mm x 25mm, pair, #ZH24	H0455	32.35	29.41

H0200



H0380



H0400



H0450



## CUTLER'S RIVETS - SOLID BRASS, SETS OF 1 SPUR AND 1 SHEATH

✓ 6mm head x 8mm shaft, 11mm max material, 10sets	H0090	6.07	5.52
✓ 6mm head x 10mm shaft, 15mm max material, 10sets	H0091	6.84	6.22
✓ 8.5mm head x 16mm shaft, 25mm max material, 6 sets	H0092	9.37	8.52

H0090



## THREADED INSERTS FOR WOOD - SOLID BRASS

✓ Insert, Threaded, Brass, 3mm, pair	H3900	3.85	3.50
✓ Insert, Threaded, Brass, 3mm, dozen	H3901	13.85	12.59
✓ Insert, Threaded, Brass, 4mm, pair	H3902	4.06	3.69
✓ Insert, Threaded, Brass, 4mm, dozen	H3903	14.62	13.29
✓ Insert, Threaded, Brass, 5mm, pair	H3914	4.13	3.76
✓ Insert, Threaded, Brass, 5mm, dozen	H3915	14.88	13.53
✓ Insert, Threaded, Brass, 6mm, pair	H3904	5.36	4.87
✓ Insert, Threaded, Brass, 6mm, dozen	H3905	19.29	17.54
✓ Insert, Threaded, Brass, 8mm, pair	H3906	7.23	6.57
✓ Insert, Threaded, Brass, 8mm, dozen	H3907	26.01	23.65
✓ Insert, Threaded, Brass, 1/4 inch, pair	H3908	5.54	5.04
✓ Insert, Threaded, Brass, 1/4 inch, dozen	H3909	19.94	18.13
✓ Insert, Threaded, Brass, 5/16 inch, pair	H3910	5.54	5.04
✓ Insert, Threaded, Brass, 5/16 inch, dozen	H3911	19.94	18.13
✓ Insert, Threaded, Brass, 3/8 inch, pair	H3912	7.23	6.57
✓ Insert, Threaded, Brass, 3/8 inch, dozen	H3913	26.01	23.65

H3900



## BRUSSO BOX AND CABINET HARDWARE

Wood Works supplies a range of box and cabinet hardware made in the USA by the Brusso Corporation. More complete descriptions can be found on our website - search using the word brusso. Note the majority of the range is also available in stainless steel.

### PIVOT HINGES - OFFSET - BRASS

✓ 33.34mm x 7.94mm leaf, Pair, #L-23	H7060	28.88	26.25
✓ 44.45mm x 9.53mm leaf, Pair, #L-37	H7062	33.29	30.26
✓ Long Knuckle, 44.45mm x 9.53mm leaf, Pair, #L-39	H7064	34.55	31.40
✓ Brass, 50.80mm x 12.7mm leaf, Pair, #L-87	H7066	50.30	45.72

H7060



### PIVOT HINGES - INLINE - BRASS

✓ 33.34mm x 7.94mm leaf, Pair, #ST-12	H7090	18.80	17.09
✓ 44.45mm x 9.53mm leaf, Pair, #ST-18	H7092	24.47	22.24
✓ 50.80mm x 12.7mm leaf, Pair, #ST-80	H7094	39.59	35.99

H7090



**BUTT HINGES - BRASS**

✓ Lift Off, 63.50mm x 44.45mm, LEFT HAND, Pair	H7120	37.07	33.70
✓ Lift Off, 63.50mm x 44.45mm, RIGHT HAND, Pair	H7121	37.07	33.70
✓ Triple Knuckle with Finial, 63.50mm x 44.45mm, Pair	H7122	76.76	69.78
✓ Full Mortise, 63.50mm x 46.04mm, Pair	H7123	27.62	25.10
✓ With Finial, Full Mortise, 63.50mm x 46.04mm, Pair	H7125	31.40	28.54
✓ Full Mortise, 63.50mm x 20.64mm, Pair	H7127	29.51	26.82
✓ With Finial, Full Mortise, 31.75mm x 20.64mm, Pair	H7129	33.29	30.26
✓ Full Mortise, 31.75mm x 26.99mm, Pair	H7131	30.14	27.40
✓ With Finial, Full Mortise, 31.75mm x 31.75mm, Pair	H7133	36.44	33.12
✓ Full Mortise, 50.8mm x 38.10mm, Pair	H7135	57.23	52.02
✓ Butt with Finial, Full Mortise, 50.8mm x 38.10mm, Pair	H7137	61.01	55.46

H7125



H7150

**BOX FEET - BRASS**

✓ 12.7mm diam., Proj. 9.53 mm, Pin diam 7.94 mm, 4 pcs	H7150	15.02	13.65
✓ 19.05mm diam., Proj. 14.29 mm, Pin diam. 12.70 mm, 4 pc	H7152	32.03	29.11
✓ 25.40mm diam., Proj. 3.18 mm, Pin diam. 15.88 mm	H7154	21.95	19.95
✓ 12.70mm diam., Proj. 23.81mm, Pin diam. 9.53 mm, 4 pcs	H7156	17.54	15.94
✓ 22.23 x 22.23mm, Thickness 6mm , 4 pcs	H7158	26.36	23.96



H7180

**BOX HINGES - BRASS - BUTT - 95 deg STAYED**

✓ 19.05mm long x 12.70mm wide, Pair, #JB-101	H7180	28.88	26.25
✓ 31.75mm long x 12.70mm wide, Pair, #JB-102	H7182	31.40	28.54
✓ 31.75mm long x 15.88mm wide, Pair, #JB-103	H7184	33.92	30.83
✓ 50.80mm long x 22.23mm wide, Pair, #JB-107	H7186	59.12	53.74
✓ 31.75mm long x 25.40mm wide, Pair, #JB-804	H7188	35.18	31.98



H7220

H7222

**BOX HOOKS - BRASS**

✓ 9.53mm diam., Proj. 23.81 mm, Pin diam.4.76mm, Ea.	H7220	6.20	5.63
✓ 41.28mm diam., Proj. 28.58 mm, Pin diam. 9.53mm, Ea.	H7222	39.59	35.99



**HANGING BRACKETS**

✓ Bracket, Hanging, Brass, 38.10mm x 15.88mm, Pair	H7240	15.02	13.65
--	-------	-------	-------

H7240

H7260

**BOX KNOBS - SOLID BRASS**

✓ 7.94mm diam., 7.94mm Proj., with 4.76mm pin, Each	H7260	4.94	4.49
✓ 11.11mm diam., 9.53mm Proj., with 4.76mm pin, Each	H7262	5.57	5.06
✓ 14.29mm diam., 12.70mm Proj., with 7.94mm pin, Each	H7264	6.83	6.20
✓ 17.46mm diam., 15.88mm Proj., with 9.53mm pin, Each	H7266	8.09	7.35



**BOX LID STAYS - BRASS - PRICE FOR EACH**

✓ 73.03 x 6.35mm Body,12.70mm deep, Anchor pin 6.35mm	H7280	24.47	22.24
✓ 109.54x9.53mm Body, 19.05mm deep, Anchor pin 11.11mm	H7281	45.89	41.71

H7280

**BOX QUADRANT HINGES - BRASS**

✓ Stayed at 95 degrees, each leaf 25.40mm x 25.40mm, Pair	H7290	50.93	46.30
✓ Stayed at 95 degrees, each leaf 38.10mm x 44.45mm, Pair	H7291	75.50	68.63



H7290

**SHELF PINS & SOCKETS - BRASS**

✓ Socket, 3/8 in. (9.53mm) dia.x 7/16 in.(11.11mm), per Doz.	H7310	16.28	14.80
✓ Pin, 1/4 inch (6.35mm) diam.x3/8 inch (9.53mm), per 4	H7312	16.28	14.80

**LATCHES & CATCHES - BRASS**

✓ Latch, Mortise, Brass, 50.80mm x 19.05mm, Ea.	H7330	38.33	34.84
✓ Catch, Ball, Brass, with Keeper, 6.35mm diam., Ea.	H7332	9.98	9.07
✓ Catch, Ball, Brass, with Keeper, 8.73mm diam., Ea.	H7334	11.87	10.79
✓ Catch, Ball, Brass, with Keeper, 11.11mm diam., Ea.	H7336	13.76	12.50



**BOX HARDWARE FITTING TEMPLATES**

- ✓ Template, Each, #TJ-101
- ✓ Template, Each, #TJ-102
- ✓ Template, Each, #TJ-103
- ✓ for HD-638 Quadrant Hinge , Each, #TJ-638
- ✓ for HD-680 Quadrant Hinge , Each, #TJ-680
- ✓ for Series HD-702 Box Feet , Each, #TJ-702
- ✓ for Series JB-804 Series , Each, #TJ-804
- ✓ for Series JB-828 Series Latches, Each, #TJ-828
- ✓ for Series JB-766 Series Pulls, Each, #T-766
- ✓ for Series JB-804 Butt Hinges , Each, #T-804
- ✓ for Series 828 Push Button Latches , Each, #T-828

H7420	42.74	38.85
H7421	42.74	38.85
H7422	42.74	38.85
H7423	42.74	38.85
H7424	42.74	38.85
H7425	42.74	38.85
H7426	42.74	38.85
H7427	42.74	38.85
H7428	42.74	38.85
H7429	42.74	38.85
H7430	42.74	38.85

H7330



**ESCUTCHEON PINS- BRASS PLATED STEEL**

- ✓ 6mm x 1.5mm x 2.5mm Head Diam., per 100
- ✓ 6mm x 1.5mm x 2.5mm Head Diam., per 500
- ✓ 8mm x 1.5mm x 2.5mm Head Diam., per 100
- ✓ 8mm x 1.5mm x 2.5mm Head Diam., per 500
- ✓ 10mm x 1.5mm x 2.5mm Head Diam., per 100
- ✓ 10mm x 1.5mm x 2.5mm Head Diam., per 500
- ✓ 13mm x 1.5mm x 2.65mm Head Diam., per 100
- ✓ 13mm x 1.5mm x 2.65mm Head Diam., per 500
- ✓ 16mm x 1.5mm x 2.85mm Head Diam., per 100
- ✓ 16mm x 1.5mm x 2.85mm Head Diam., per 500
- ✓ 19mm x 1.5mm x 3.0mm Head Diam., per 100
- ✓ 19mm x 1.5mm x 3.0mm Head Diam., per 500

ITEM	RRP	Ex GST
H2001	9.59	8.72
H2002	29.98	27.25
H2003	8.76	7.96
H2004	31.27	28.43
H2005	11.38	10.34
H2006	40.64	36.94
H2007	10.57	9.60
H2008	40.64	36.94
H2009	12.75	11.59
H2010	53.14	48.31
H2011	13.75	12.50
H2012	68.75	62.50

**ESCUTCHEON PINS- SOLID BRASS**

- ✓ 8mm x 1.0mm x 1.8mm Head Diam., per 100
- ✓ 8mm x 1.0mm x 1.8mm Head Diam., per 500
- ✓ 10mm x 1.0mm x 2.3mm Head Diam., per 100
- ✓ 10mm x 1.0mm x 2.3mm Head Diam., per 500
- ✓ 10mm x 2.0mm x 4.0mm Head Diam., per 100
- ✓ 10mm x 2.0mm x 4.0mm Head Diam., per 500
- ✓ 12mm x 1.2mm x 2.30mm Head Diam., per 100
- ✓ 12mm x 1.2mm x 2.30mm Head Diam., per 500
- ✓ 12mm x 2.0mm x 4.0mm Head Diam., per 100
- ✓ 12mm x 2.0mm x 4.0mm Head Diam., per 500
- ✓ 15mm x 1.0mm x 2.5mm Head Diam., per 100
- ✓ 15mm x 1.0mm x 2.5mm Head Diam., per 500
- ✓ 15mm x 2.0mm x 2.8mm Head Diam., per 100
- ✓ 15mm x 2.0mm x 2.8mm Head Diam., per 500
- ✓ 15mm x 1.5mm x 3.0mm Head Diam., per 100
- ✓ 15mm x 1.5mm x 3.0mm Head Diam., per 500
- ✓ 20mm x 1.5mm x 3.0mm Head Diam., per 100
- ✓ 20mm x 1.5mm x 3.0mm Head Diam., per 500
- ✓ 25mm x 1.5mm x 3.0mm Head Diam., per 100
- ✓ 25mm x 1.5mm x 3.0mm Head Diam., per 500
- ✓ 30mm x 2.0mm x 4.0mm Head Diam., per 100
- ✓ 30mm x 2.0mm x 4.0mm Head Diam., per 500

H2050	11.26	10.24
H2051	45.04	40.94
H2052	12.62	11.48
H2053	50.49	45.90
H2054	19.37	17.61
H2055	77.49	70.45
H2056	13.75	12.50
H2057	55.00	50.00
H2058	21.88	19.89
H2059	87.51	79.55
H2060	15.63	14.21
H2061	62.53	56.84
H2062	15.63	14.21
H2063	62.53	56.84
H2064	24.75	22.50
H2065	99.00	90.00
H2066	27.50	25.00
H2067	110.00	100.00
H2068	32.50	29.55
H2069	130.02	118.20
H2070	43.75	39.77
H2071	175.00	159.09



**SCREWS**

- ✓ Screws, Brass Plated, 4mm x 1.7mm, pkt approx 100
- ✓ Screws, Brass Plated, 5mm x 2.0mm, pkt approx 100
- ✓ Screws, Brass Plated, 6mm x 1.7mm, pkt approx 100
- ✓ Screws, Brass Plated, 6mm x 2.0mm, pkt approx 100
- ✓ Screws, Brass Plated, 8mm x 2.3mm, pkt approx 100
- ✓ Screws, Brass Plated, 10mm x 2.3mm, pkt approx 100
- ✓ Screws, Brass Plated, 12mm x 2.0mm, pkt approx 100
- ✓ Screws, Brass Plated, 12mm x 2.3mm, pkt approx 100
- ✓ Screws, Steel, Nickel Plated, 8 x 2.0mm, pkt approx 100
- ✓ Screws, Steel, Nickel Plated, 10 x 2.0mm, pkt approx 100

ITEM	RRP	Ex GST
H5200	7.19	6.54
H5201	7.80	7.09
H5202	8.41	7.64
H5203	8.41	7.64
H5204	10.20	9.28
H5205	10.20	9.28
H5206	12.61	11.46
H5207	12.61	11.46
H5400	0.00	0.00
H5401	0.00	0.00

H5200  
to  
H5401



### RARE EARTH MAGNETS

- ✓ Disc, Neodymium, 6mm diam x 2mm thick, pkt 4
- ✓ Disc, Neodymium, 6mm diam x 2mm thick, pkt 12
- ✓ Disc, Neodymium, 8mm diam x 5.0mm thick, 4 pcs
- ✓ Disc, Neodymium, 10mm diam x 1.5mm thick, 4 pcs
- ✓ Disc, Neodymium, 10mm diam x 3.0mm thick, 4 pcs
- ✓ Disc, Neodymium, 12mm diam x 5.0mm thick, 4 pcs
- ✓ Disc, Neodymium, 12mm diam x 6.6mm thick, 4 pcs

ITEM	RRP	Ex GST
H6000	6.05	5.50
H6001	18.15	16.50
H6002	9.68	8.80
H6003	7.26	6.60
H6004	11.00	10.00
H6005	23.65	21.50
H6006	31.46	28.60



### MEDIA STORAGE

These storage racks for DVD, CD & VHS Tape cases are an ideal basis for a school project. Spring finger racks hold in place by the pressure from spring loaded plastic fingers which partly eject the case when it is pressed and disengaged from the rack. These racks are suited to tower use or used flat on their backs in a drawer arrangement.

#### SPRING FINGER STYLE RACK - LH & RH SET

- ✓ CD Insert, holds 20, 1 set, #4196
- ✓ CD Insert, holds 20, 100 Sets, #4196
- ✓ CD Insert, Half Height, holds 10, 1 set, #4141
- ✓ CD Insert, Half Height, holds 10, 100 Sets, #4141
- ✓ CD Insert, for Double CD Case, holds 10, 1 set, #4198
- ✓ CD Insert, for Double CD Case, holds 10, 100 Sets, #419
- ✓ DVD Insert, holds 15, 1 set, #4161
- ✓ DVD Insert, holds 15, 100 sets, #4161

ITEM	RRP	Ex GST
P0120	9.50	8.64
P0125	708.75	644.32
P0130	8.59	7.81
P0135	427.50	388.64
P0140	12.97	11.79
P0145	765.00	695.45
P0150	11.88	10.80
P0155	708.75	644.32

#### GRILLE STYLE

- ✓ Rack, CD, Grille Style, holds 9, each, #FWCD-9V
- ✓ Rack, CD, Grille Style, holds 9, 200 pcs, #FWCD-9V
- ✓ Rack, DVD, Grille Style, holds 7, each, #FWDVD-7V
- ✓ Rack, DVD, Grille Style, holds 7, 200 pcs, #FWDVD-7V

P0160	4.58	4.16
P0161	378.00	343.64
P0170	4.87	4.43
P0171	522.00	474.55

#### DRAWER STYLE - LH & RH SET

- ✓ Tray, CD Storage, for Drawer, holds 26 CD's, 1 set
- ✓ Tray, CD Storage, for Drawer, holds 26 CD's, 100 sets
- ✓ Tray, DVD Storage, for Drawer, holds 13 DVD's, 1 set
- ✓ Tray, DVD Storage, for Drawer, holds 13 DVD's, 100 sets

P0180	6.83	6.21
P0181	483.75	439.77
P0195	6.83	6.21
P0196	483.75	439.77

#### TOWER STYLE RACKS

- ✓ D Style, for CD Storage, holds 8 CD's, each
- ✓ D Style, for CD Storage, holds 8 CD's, 120 pcs
- ✓ D Style, for CD Storage, holds 15 CD's, each
- ✓ D Style, for CD Storage, holds 15 CD's, 100 pcs

P0205	4.97	4.52
P0206	243.00	220.91
P0210	4.97	4.52
P0211	213.75	194.32

### BALL-POINT PEN MAKING ON THE LATHE

These ball point pen mechanisms allow turned pens to be made on the lathe. A mandrell to hold the pen sections is strongly advised and a pen mill to square the ends on the sections prior to turning helps produce a high quality result. The brass tubes require a brad point 7mm drill

- ✓ DATA SHEET - Making Twist-Action Ball-Point Pens
- ✓ Pen Sets, Ball Point Twist, Gold Clip, pkt 5
- ✓ Pen Sets, Ball Point Twist, Plain Black Clip, pkt 5
- ✓ Pen Sets, Ball Point Twist, Australia Black Clip, pkt 5
- ✓ Tube, 7mm Brass, Spare, 6 pcs
- ✓ Mandrell, Pen, for dual 7mm Core tubes, #2 Morse Taper
- ✓ Mill, Pen, for 7mm bore tube
- ✓ Drill, Brad Point, 7mm, Stubai

ITEM	RRP	Ex GST
DS001	2.00	1.82
P0003	24.95	22.68
P0001	24.95	22.68
P0005	24.95	22.68
P0029	3.20	2.91
A0295	39.00	35.45
A0299	54.00	49.09
T3534	6.50	5.91

### Spring Finger Styles



### Drawer Styles



P0003 - P0005

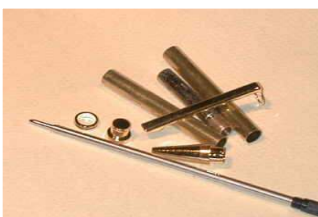

A0295



A0299



T3534



## SALT & PEPPER MILL GRINDERS ON THE LATHE

Salt and pepper mills are a popular project for wood turners. The ready availability of mechanisms - metal for pepper and hard plastic for salt - requires only the mill body and top to be made. Any wood can be used with the possible exception of highly scented or resinous woods which may tend to taint the contents.

- ✓ Mill, Salt, Kit, Silver Knob, 5 inch, #S1005
- ✓ Mill, Salt, Kit, Silver Knob, 7 inch, #S1010
- ✓ Mill, Salt, Kit, Silver Knob, 8 inch, #S1015
- ✓ Mill, Salt, Kit, Silver Knob, 10 inch, #S1020
- ✓ Mill, Salt, Kit, Silver Knob, 12 inch, #S1030
- ✓ Mill, Salt, Kit, Silver Knob, 15 inch, #S1040
- ✓ Mill, Salt, Kit, Silver Knob, 17 inch, #S1050

- ✓ Mill, Salt, Kit, Brass Knob, 5 inch, #S1005B
- ✓ Mill, Salt, Kit, Brass Knob, 7 inch, #S1010B
- ✓ Mill, Salt, Kit, Brass Knob, 8 inch, #S1015B
- ✓ Mill, Salt, Kit, Brass Knob, 10 inch, #S1020B
- ✓ Mill, Salt, Kit, Brass Knob, 12 inch, #S1030B
- ✓ Mill, Salt, Kit, Brass Knob, 15 inch, #S1040B
- ✓ Mill, Salt, Kit, Brass Knob, 17 inch, #S1050B

- ✓ Mill, Pepper, Kit, Black Knob, 5 inch, #S2005
- ✓ Mill, Pepper, Kit, Black Knob, 7 inch, #S2010
- ✓ Mill, Pepper, Kit, Black Knob, 8 inch, #S2015
- ✓ Mill, Pepper, Kit, Black Knob, 10 inch, #S2020
- ✓ Mill, Pepper, Kit, Black Knob, 12 inch, #S2030
- ✓ Mill, Pepper, Kit, Black Knob, 15 inch, #S2040
- ✓ Mill, Pepper, Kit, Black Knob, 17 inch, #S2050

- ✓ Mill, Pepper, Kit, Brass Knob, 5 inch, #S2005B
- ✓ Mill, Pepper, Kit, Brass Knob, 7 inch, #S2010B
- ✓ Mill, Pepper, Kit, Brass Knob, 8 inch, #S2015B
- ✓ Mill, Pepper, Kit, Brass Knob, 10 inch, #S2020B
- ✓ Mill, Pepper, Kit, Brass Knob, 12 inch, #S2030B
- ✓ Mill, Pepper, Kit, Brass Knob, 15 inch, #S2040B
- ✓ Mill, Pepper, Kit, Brass Knob, 17 inch, #S2050B

ITEM	RRP	Ex GST
P0720	10.09	9.17
P0721	10.26	9.33
P0722	10.46	9.51
P0723	10.85	9.86
P0724	11.05	10.04
P0725	11.63	10.57
P0726	11.73	10.66
P0728	9.50	8.64
P0729	9.68	8.80
P0730	9.87	8.98
P0731	10.26	9.33
P0732	10.46	9.51
P0733	11.05	10.04
P0734	11.14	10.13
P0736	10.09	9.17
P0737	10.26	9.33
P0738	10.46	9.51
P0739	10.85	9.86
P0740	11.05	10.04
P0741	11.63	10.57
P0742	11.73	10.66
P0744	9.50	8.64
P0745	9.68	8.80
P0746	9.87	8.98
P0747	10.26	9.33
P0748	10.46	9.51
P0749	11.05	10.04
P0750	11.14	10.13

### Pepper Kits



### Salt Kits



## MILL MAKING EQUIPMENT

- ✓ Drill, HSS, Jobber, Brad Point, #2 Morse Drive, 24.0mm
- ✓ Borer, Universal, 35mm, Stubai
- ✓ Drill, Brad Point, 6mm, Stubai

ITEM	RRP	Ex GST
T3833	165.00	150.00
T0339	40.28	36.62
T3533	5.45	4.96

T3833



T0339



T3533



## TOY WHEEL CUTTERS

- ✓ Cutter, Toy Wheel, 40mm TWC40 1/2
- ✓ Cutter, Toy Wheel, 50mm TWC 50 1/2
- ✓ Cutter, Toy Wheel, 60mm TWC 60 1/2

T0200	108.65	98.77
T0202	115.50	105.00
T0201	115.50	105.00

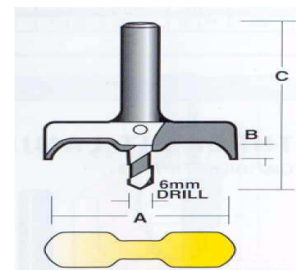

**INSERT & CONCEALED MECHANISM QUARTZ CLOCKS**

Concealed mechanism clocks can be recessed into the rear side of a piece of wood and hands fitted to the shank which protrudes through the body. There are numerous hand patterns to suit concealed mechanism clocks and numerals in Arabic & Roman styles. Purchase price of items P4007, P4008 & P4009 includes a set of hands and numerals of choice. Insert clocks can be pressed into a machined or drilled front recess. Batteries are not supplied.

**CONCEALED QUARTZ MECHANISMS**

- ✓ Clock, with numerals & hands, 8mm short shaft
- ✓ Clock, with numerals & hands, 15mm medium shaft
- ✓ Clock, with numerals & hands, 21mm long shaft

ITEM	RRP	Ex GST
P4007	10.95	9.95
P4008	10.95	9.95
P4009	10.95	9.95

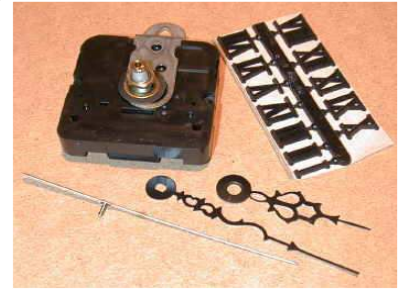

**CLOCK FACE NUMERALS**

- ✓ ARABIC GOLD, 10mm (3/8inch)
- ✓ ARABIC GOLD, 16mm (5/8inch)
- ✓ ARABIC GOLD, 19mm (3/4inch)
- ✓ ARABIC GOLD, 25mm (1inch)
  
- ✓ ARABIC BLACK, 10mm (3/8 inch)
- ✓ ARABIC BLACK, 16mm (5/8inch)
- ✓ ARABIC BLACK, 19mm (3/4 inch)
- ✓ ARABIC BLACK, 25mm (1 inch)
  
- ✓ ROMAN GOLD, 10mm (3/8 inch)
- ✓ ROMAN GOLD, 16mm (5/8inch)
- ✓ ROMAN GOLD, 19mm (3/4inch)
- ✓ ROMAN GOLD, 25mm (1 inch)

ITEM	RRP	Ex GST
P4150	2.80	2.54
P4151	3.26	2.97
P4152	3.59	3.26
P4153	3.88	3.52

P0241	2.80	2.54
P4155	3.26	2.97
P0247	3.96	3.60
P0249	3.96	3.60
P0231	2.80	2.54
P4157	3.26	2.97
P4158	3.59	3.26
P0239	3.96	3.60



- ✓ ARABIC WITH DOTS GOLD, 16mm (5/8inch)
- ✓ ARABIC WITH DOTS GOLD, 19mm (3/4inch)
  
- ✓ ROMAN WITH DOTS GOLD, 16mm (5/8inch)

P4160	4.81	4.37
P4161	5.14	4.67
P4163	3.59	3.26



**CLOCK FACE HANDS FOR CONCEALED QUARTZ MOVEMENTS**

For pictures of clock hand patterns search using the Item Code in the SEARCH FOR BOX on the HOME PAGE at [www.thewoodworks.com.au](http://www.thewoodworks.com.au)

**for 50mm to 80mm DIALS**

- ✓ for 50mm to 80mm DIALS, 35mm, GOLD, Type B
- ✓ for 50mm to 80mm DIALS, 35mm, Black, Type B
- ✓ for 50mm to 80mm DIALS, 35mm, Gold, Type C
- ✓ for 50mm to 80mm DIALS, 35mm, Black, Type C
- ✓ for 50mm to 80mm DIALS, 38mm, Gold, Type D
- ✓ for 50mm to 80mm DIALS, 38mm, Gold, Type E
- ✓ for 50mm to 80mm DIALS, 38mm, Black, Type E

ITEM	RRP	Ex GST
P4041	2.52	2.29
P4042	2.52	2.29
P4043	2.52	2.29
P4044	2.52	2.29
P4045	2.52	2.29
P4046	2.52	2.29
P4047	2.52	2.29

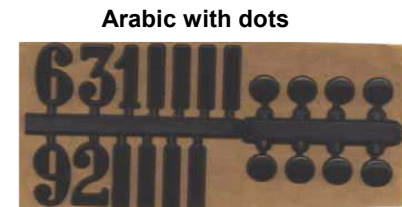

**for 90mm to 125mm DIALS**

- ✓ for 90mm to 125mm DIALS, 44mm, Gold, Type A
- ✓ for 90mm to 125mm DIALS, 48mm, Gold, Type B
- ✓ for 90mm to 125mm DIALS, 48mm, Black, Type B
- ✓ for 90mm to 125mm DIALS, 52mm, Gold, Type C
- ✓ for 90mm to 125mm DIALS, 52mm, Black, Type C
- ✓ for 90mm to 125mm DIALS, 52mm, Gold, Type D
- ✓ for 90mm to 125mm DIALS, 54mm, Black, Type E
- ✓ for 90mm to 125mm DIALS, 57mm, Gold, Type F
- ✓ for 90mm to 125mm DIALS, 57mm, Black, Type F
- ✓ for 90mm to 125mm DIALS, 64mm, Gold, Type G
- ✓ for 90mm to 125mm DIALS, 64mm, Black, Type G

P4060	2.52	2.29
P4061	2.52	2.29
P4062	2.52	2.29
P4063	2.52	2.29
P4064	2.52	2.29
P4065	2.52	2.29
P4066	2.52	2.29
P4067	2.52	2.29
P4068	2.52	2.29
P4069	2.52	2.29
P4070	2.52	2.29



### for 150mm to 210mm DIALS

- ✓ for 150mm to 210mm DIALS, 76mm, Gold, Type A
- ✓ for 150mm to 210mm DIALS, 76mm, Black, Type A
- ✓ for 150mm to 210mm DIALS, 79mm, Gold, Type B
- ✓ for 150mm to 210mm DIALS, 79mm, Black, Type B
- ✓ for 150mm to 210mm DIALS, 86mm, Black, Type C
- ✓ for 150mm to 210mm DIALS, 89mm, Gold, Type D
- ✓ for 150mm to 210mm DIALS, 89mm, Black, Type D
- ✓ for 150mm to 210mm DIALS, 103mm, Black, Type E
- ✓ for 150mm to 210mm DIALS, 105mm, Gold, Type F
- ✓ for 150mm to 210mm DIALS, 105mm, Black, Type F

### HANDS- SECOND HAND SWEEPS

- ✓ for Quartz Clock Movement, 61mm, Gold, Type G
- ✓ for Quartz Clock Movement, 61mm, Black, Type G
- ✓ for Quartz Clock Movement, 61mm, Red, Type G

### INSERT CLOCK MECHANISMS / MOVEMENTS

- ✓ 36mm diameter, GOLD ARABIC
- ✓ 36mm diameter, GOLD ROMAN
- ✓ 36mm diameter, WHITE ARABIC
- ✓ 36mm diameter, WHITE ROMAN
- ✓ 36mm diameter, BLACK ARABIC
- ✓ 36mm diameter, BLACK ROMAN
- ✓ 36mm diameter, CREAM ARABIC
- ✓ 36mm diameter, CREAM ROMAN
  
- ✓ 50mm diameter, GOLD ROMAN
- ✓ 50mm diameter, WHITE ROMAN
- ✓ 50mm diameter, GOLD ARABIC
- ✓ 50mm diameter, WHITE ARABIC
- ✓ 50mm diameter, BLACK ROMAN
  
- ✓ 73mm diameter, GOLD ARABIC
- ✓ 73mm diameter, GOLD ROMAN
- ✓ 73mm diameter, WHITE FANCY ARABIC
- ✓ 73mm diameter, WHITE FANCY ROMAN
- ✓ 73mm diameter, IVORY FANCY ARABIC
- ✓ 73mm diameter, IVORY FANCY ROMAN
  
- ✓ 90mm diameter, GOLD ARABIC
- ✓ 90mm diameter, GOLD ROMAN
- ✓ 90mm diameter, WHITE FANCY ARABIC
- ✓ 90mm diameter, WHITE FANCY ROMAN
- ✓ 90mm diameter, IVORY FANCY ARABIC
- ✓ 90mm diameter, IVORY FANCY ROMAN
- ✓ 90mm diameter, BLACK ROMAN
  
- ✓ 130mm diameter, IVORY FANCY ARABIC
- ✓ 130mm diameter, GOLD ROMAN
- ✓ 130mm diameter, GOLD ARABIC
  
- ✓ 160mm diameter, GOLD ROMAN
- ✓ 160mm diameter, IVORY FANCY ARABIC
- ✓ 160mm diameter, GOLD ARABIC

### HOT BREAD KNIFE KITS

- ✓ Knife, Blade, Hot Bread, #C3005
- ✓ Cover, for Hot Bread Knife, #C3020

P4080	2.95	2.68
P4081	2.95	2.68
P4082	2.95	2.68
P4083	2.95	2.68
P4084	2.95	2.68
P4085	2.95	2.68
P4086	2.95	2.68
P4087	2.95	2.68
P4088	2.95	2.68
P4089	2.95	2.68

P4110	2.34	2.13
P4111	2.34	2.13
P4112	2.34	2.13

P3000	23.98	21.80
P3001	23.98	21.80
P3002	23.98	21.80
P3003	23.98	21.80
P3004	23.98	21.80
P3005	23.98	21.80
P3006	23.98	21.80
P3007	23.98	21.80

P3020	27.94	25.40
P3021	27.94	25.40
P3022	27.94	25.40
P3023	27.94	25.40
P3024	27.94	25.40

P3040	28.60	26.00
P3041	28.60	26.00
P3042	28.60	26.00
P3043	28.60	26.00
P3044	28.60	26.00
P3045	28.60	26.00

P3060	28.60	26.00
P3061	28.60	26.00
P3062	28.60	26.00
P3063	28.60	26.00
P3064	28.60	26.00
P3065	28.60	26.00
P3066	28.60	26.00

P3080	52.14	47.40
P3081	52.14	47.40
P3082	52.14	47.40

P3090	59.07	53.70
P3091	59.07	53.70
P3092	59.07	53.70

P0590	poa	poa
P0593	poa	poa

### Example hand set



P3020



# CONSUMABLES

## ADHESIVES

All our PVA range is made in Australia from quality fresh ingredients.

Our renowned "yellow" PVA has superior strength, good sandability and quick cure.

The crosslinking PVA has the strongest bond of them all.

The White Sandable is an ultra hard cure PVA which cures slowly & allows time for complex glue ups.

## PVA Glues



	ITEM	RRP	Ex GST
✓ White Crosslinking PVA, T3275, 500ml, (decant)	C0097	12.37	11.24
✓ White Crosslinking PVA, T3275, 1 Litre, (decant)	C0098	15.20	13.82
✓ White Crosslinking PVA, T3275, 5 litres, (decant)	C0099	54.00	49.09
✓ White Crosslinking PVA, T3275, 20 litres	C0100	190.40	173.09
✓ White Sandable PVA, Slow Cure, T3223, 500ml, (decant)	C0103	11.84	10.77
✓ White Sandable PVA, Slow Cure, T3223, 1 Litre, (decant)	C0104	14.40	13.09
✓ White Sandable PVA, Slow Cure, T3223, 5 Litres (decant)	C0105	50.40	45.82
✓ White Sandable PVA, Slow Cure, T3223, 20 Litres	C0106	176.80	160.73
✓ Water Resistant, Yellow PVA, T3250, 500ml, (decant)	C0109	11.46	10.42
✓ Water Resistant, Yellow PVA, T3250, 1 Litre, (decant)	C0110	13.82	12.56
✓ Water Resistant, Yellow PVA, T3250, 5 Litres (decant)	C0111	47.79	43.45
✓ Water Resistant, Yellow PVA, T3250, 20 Litres	C0112	166.94	151.76

## ANIMAL PROTEIN GLUE

✓ Adhesive, Hide, Pearl Joiners, 1kg	C0081	19.20	17.45
✓ Adhesive, Hide, Pearl Joiners, 2kg	C0082	35.50	32.27
✓ Adhesive, Hide, Pearl Joiners, 5kg	C0083	84.95	77.23

## BISCUITS

	ITEM	RRP	Ex GST
✓ Biscuits, #0, pkt 100	C0400	9.90	9.00
✓ Biscuits, #10, pkt 100	C0401	9.90	9.00
✓ Biscuits, #20, pkt 100	C0402	9.90	9.00
✓ Biscuits, #0, box 1000	C0410	62.70	57.00
✓ Biscuits, #10, box 1000	C0411	65.00	59.09
✓ Biscuits, #20, box 1000	C0412	65.00	59.09

## Biscuits



## FLUTED DOWEL - TASMANIAN OAK - CUT TO LENGTH

✓ 6mm x 38mm, 72 grams (approx. 100 pcs)	C0414	5.90	5.36
✓ 6mm x 38mm, 720 gms (approx 1000 pcs)	C0415	58.98	53.62
✓ 8mm x 44mm, 141 grams (approx 100 pcs)	C0416	6.56	5.96
✓ 8mm x 44mm, 1410 grams (approx 1000 pcs)	C0417	65.61	59.64
✓ 8mm x 50mm, 158 grams (approx 100 pcs)	C0418	7.46	6.78
✓ 8mm x 50mm, 1580 grams (approx. 1000 pcs)	C0419	74.56	67.78
✓ 10mm x 44mm, 248 grams (approx 100 pcs)	C0420	256.00	232.73
✓ 10mm x 44mm, 2480 grams (approx 1000 pcs)	C0421	93.57	85.06
✓ 10mm x 50mm, 282 grams (approx. 100 pcs)	C0422	10.63	9.67
✓ 10mm x 50mm, 2820 gms (approx. 1000 pcs)	C0423	106.33	96.67
✓ 10mm x 62mm, 349 grams (approx 100 pcs)	C0424	13.19	11.99
✓ 10mm x 62mm, 3490 grams (approx 1000 pcs)	C0425	131.86	119.88

## Dowels



## FESTO DOMINO SLIP TENONS

✓ 5 x 30mm, 1800 pcs (6 pks x 300), #493 296	C0394	184.00	167.27
✓ 6 x 40mm, 1140 pcs (6 pks x 190), #493 297	C0395	184.00	167.27
✓ 8 x 40mm, 780 pcs (6 pks x 130), #493 298	C0396	184.00	167.27
✓ 8 x 50mm, 600 pcs (6 pks x 100), #493 299	C0397	184.00	167.27
✓ 10 x 50mm, 510 pcs (6 pks x 85), #493 300	C0398	184.00	167.27

## Dominos



## PICTURE FRAMING V NAILS

✓ V Nails, 7mm Hardwood, framing, pkt 400	C0821	9.95	9.05
✓ V Nails, 10mm Hardwood, framing, pkt 400	C0822	10.95	9.95
✓ V Nails, 15mm Hardwood, framing, pkt 400	C0824	12.95	11.77

## PUTTY BRICKS - AUSTRALIAN MADE

Ideal for repair of dings & gaps. Boxes of 20 mixed colours, bags of 5 of any one colour & bags of 10 wood tones.

- ✓ 75 x 15 x 15mm, 10 WOOD TONE colours
- ✓ 75 x 15 x 15mm, 20 colours, #APB 1
- ✓ 5 pcs, 75 x 15 x 15mm, Pine, #WPB 20
- ✓ 5 pcs, 75 x 15 x 15mm, Baltic, #WPB 43

<b>C3945</b>	<b>29.98</b>	<b>27.25</b>
<b>C3946</b>	<b>49.95</b>	<b>45.41</b>
<b>C3958</b>	<b>14.95</b>	<b>13.59</b>
<b>C3981</b>	<b>14.95</b>	<b>13.59</b>

## PUTTY 'BRICKS'



## SHELLAC

Cured shellac is safe enough to be rated as a food and offers a quick and safe method of achieving a quality finish on numerous projects. The best method of ensuring a long shelf life and superior finishes is to use DAA (Denatured Absolute Alcohol) Spirits.

It is important that the DAA can be appropriately stored.

A standard concentrate is simply and quickly made up using a 1 to 4 ratio of dry shellac by weight to DAA spirits by liquid volume e.g. 500gms mixed with 2 litres of DAA.

## DAA SPIRITS

- ✓ Spirits, DAA, 100% Industrial Alcohol, 1 litre
- ✓ Spirits, DAA, 100% Industrial Alcohol, 5 litres
- ✓ Spirits, DAA, 100% Industrial Alcohol, 20 litres

ITEM	RRP	Ex GST
<b>C2271</b>	<b>141.00</b>	<b>128.18</b>
<b>C2272</b>	<b>0.00</b>	<b>0.00</b>
<b>C2273</b>	<b>ERR</b>	<b>ERR</b>

## DRY SHELLACS

- ✓ Shellac, Orange Flake, Waxy, 125gms
- ✓ Shellac, Orange Flake, Waxy, 250gms
- ✓ Shellac, Orange Flake, Waxy, 500gms
- Shellac, Orange Flake, Waxy, 1 kilo
- Shellac, Orange Flake, Waxy, 5 kilo
  
- ✓ Shellac, Button, Waxy, 125gms
- ✓ Shellac, Button, Waxy, 250gms
- ✓ Shellac, Button, Waxy, 500gms
- ✓ Shellac, Button, Waxy, 1 kilo
- ✓ Shellac, Button, Waxy, 5 kilo
  
- ✓ Shellac, Garnet Flake, De-Waxed, 125gms
- ✓ Shellac, Garnet Flake, De-Waxed, 250gms
- ✓ Shellac, Garnet Flake, De-Waxed, 500gms
- ✓ Shellac, Garnet Flake, De-Waxed, 1 kilo
- ✓ Shellac, Garnet Flake, De-Waxed, 5 kilo
  
- ✓ Shellac, Ruby Flake, De-Waxed 125gms
- ✓ Shellac, Ruby Flake, De-Waxed 250gms
- ✓ Shellac, Ruby Flake, De-Waxed 500gms
- ✓ Shellac, Ruby Flake, De-Waxed 1 kilo
- ✓ Shellac, Ruby Flake, De-Waxed 5 kilo
  
- ✓ Shellac, Blonde, De-Waxed, Flake, 125gms
- ✓ Shellac, Blonde, De-Waxed, Flake, 250gms
- ✓ Shellac, Blonde, De-Waxed, Flake, 500gms
- ✓ Shellac, Blonde, De-Waxed, Flake, 1 kilo
- ✓ Shellac, Blonde, De-Waxed, Flake, 5 kilo
  
- ✓ Shellac, White, Waxy, Granulated, 125gms
- ✓ Shellac, White, Waxy, Granulated, 250gms
- ✓ Shellac, White, Waxy, Granulated, 500gms
- ✓ Shellac, White, Waxy, Granulated, 1 kilo
- ✓ Shellac, White, Waxy, Granulated, 5 kilo
  
- ✓ Shellac, White, De-Waxed, Granulated, 125gms
- ✓ Shellac, White, De-Waxed, Granulated, 250gms
- ✓ Shellac, White, De-Waxed, Granulated, 500gms
- ✓ Shellac, White, De-Waxed, Granulated, 1 kilo
- ✓ Shellac, White, De-Waxed, Granulated, 5 kilo

<b>C2410</b>	<b>5.83</b>	<b>5.30</b>
<b>C2411</b>	<b>10.69</b>	<b>9.72</b>
<b>C2412</b>	<b>19.44</b>	<b>17.67</b>
<b>C2413</b>	<b>32.66</b>	<b>29.69</b>
<b>C2414</b>	<b>163.28</b>	<b>148.43</b>
<b>C2420</b>	<b>12.49</b>	<b>11.35</b>
<b>C2421</b>	<b>22.89</b>	<b>20.81</b>
<b>C2422</b>	<b>41.63</b>	<b>37.84</b>
<b>C2423</b>	<b>69.93</b>	<b>63.57</b>
<b>C2424</b>	<b>349.65</b>	<b>317.86</b>
<b>C2430</b>	<b>11.63</b>	<b>10.57</b>
<b>C2431</b>	<b>21.31</b>	<b>19.38</b>
<b>C2432</b>	<b>38.75</b>	<b>35.23</b>
<b>C2433</b>	<b>65.10</b>	<b>59.18</b>
<b>C2434</b>	<b>325.50</b>	<b>295.91</b>
<b>C2440</b>	<b>12.38</b>	<b>11.25</b>
<b>C2441</b>	<b>22.69</b>	<b>20.63</b>
<b>C2442</b>	<b>41.25</b>	<b>37.50</b>
<b>C2443</b>	<b>69.30</b>	<b>63.00</b>
<b>C2444</b>	<b>346.50</b>	<b>315.00</b>
<b>C2460</b>	<b>12.90</b>	<b>11.73</b>
<b>C2461</b>	<b>23.65</b>	<b>21.50</b>
<b>C2462</b>	<b>43.00</b>	<b>39.09</b>
<b>C2463</b>	<b>72.24</b>	<b>65.67</b>
<b>C2464</b>	<b>361.20</b>	<b>328.36</b>
<b>C2490</b>	<b>12.86</b>	<b>11.69</b>
<b>C2491</b>	<b>23.58</b>	<b>21.44</b>
<b>C2492</b>	<b>42.88</b>	<b>38.98</b>
<b>C2493</b>	<b>72.03</b>	<b>65.48</b>
<b>C2494</b>	<b>360.15</b>	<b>327.41</b>
<b>C2500</b>	<b>11.79</b>	<b>10.72</b>
<b>C2501</b>	<b>21.62</b>	<b>19.66</b>
<b>C2502</b>	<b>39.31</b>	<b>35.74</b>
<b>C2503</b>	<b>66.05</b>	<b>60.04</b>
<b>C2504</b>	<b>330.23</b>	<b>300.20</b>

### Orange



### Button



### Garnet



### Ruby



### Blonde



### Waxy White



### De-Waxed White



**READY MIX - supplied in Dangerous Goods Packaging**

**REGULAR FRENCH POLISH**

✓ Orange, Ready Mixed, 1 litre DG Packed	<b>C2510</b>	<b>35.34</b>	<b>32.13</b>
✓ Orange, Ready Mixed, 5 litre DG Packed	<b>C2511</b>	<b>102.72</b>	<b>93.38</b>
✓ Waxy White, Ready Mixed, 1 litre DG Packed	<b>C2513</b>	<b>57.71</b>	<b>52.46</b>
✓ Waxy White, Ready Mixed, 5 litre DG Packed	<b>C2514</b>	<b>173.01</b>	<b>157.28</b>
✓ De Waxed White, Ready Mixed, 1 litre DG Packed	<b>C2516</b>	<b>49.83</b>	<b>45.30</b>
✓ De Waxed White, Ready Mixed, 5 litre DG Packed	<b>C2517</b>	<b>148.26</b>	<b>134.78</b>
✓ Brown, Ready Mixed, 1 litre DG Packed	<b>C2519</b>	<b>40.39</b>	<b>36.72</b>
✓ Brown, Ready Mixed, 5 litre DG Packed	<b>C2520</b>	<b>210.11</b>	<b>191.01</b>
✓ Blonde, Dewaxed, Ready Mixed, 1 litre DG Packed	<b>C2522</b>	<b>64.01</b>	<b>58.19</b>
✓ Blonde, Dewaxed, Ready Mixed, 5 litre DG Packed	<b>C2523</b>	<b>192.81</b>	<b>175.28</b>



**HARD FRENCH POLISH**

✓ Orange, Ready Mixed, HARD, 1 litre DG Packed	<b>C2526</b>	<b>123.54</b>	<b>112.31</b>
✓ Orange, Ready Mixed, HARD, 5 litre DG Packed	<b>C2527</b>	<b>379.92</b>	<b>345.38</b>
✓ Waxy White, Ready Mixed, HARD, 1 litre DG Packed	<b>C2529</b>	<b>145.91</b>	<b>132.64</b>
✓ Waxy White, Ready Mixed, HARD, 5 litre DG Packed	<b>C2530</b>	<b>450.21</b>	<b>409.28</b>
✓ De Waxed White, Ready Mixed, HARD, 1 litre DG Packed	<b>C2532</b>	<b>138.03</b>	<b>125.48</b>
✓ De Waxed White, Ready Mixed, HARD, 5 litre DG Packed	<b>C2533</b>	<b>425.46</b>	<b>386.78</b>
✓ Brown, Ready Mixed, HARD, 1 litre DG Packed	<b>C2535</b>	<b>155.04</b>	<b>140.95</b>
✓ Brown, Ready Mixed, HARD, 5 litre DG Packed	<b>C2536</b>	<b>379.92</b>	<b>345.38</b>
✓ Blonde, Dewaxed, Ready Mixed, HARD, 1 litre DG Packed	<b>C2538</b>	<b>88.11</b>	<b>80.10</b>
✓ Blonde, Dewaxed, Ready Mixed, HARD, 5 litre DG Packed	<b>C2539</b>	<b>359.91</b>	<b>327.19</b>

**Pure Tung Oil**



**FINISHING OILS & WAXES**

Our tung oil is pure whereas most formulations marketed as tung oil contain only a small amount of tung oil. Tung oil is non toxic, applicable for use as a finish on kitchen utensils and children's toys.

✓ Oil, Tung, Pure, 1 Litre	<b>C2891</b>	<b>45.94</b>	<b>41.76</b>
✓ Oil, Tung, Pure, 5 Litre	<b>C2893</b>	<b>172.44</b>	<b>156.76</b>
✓ Wax, Bees, Mirowax 738, 230gms (re-packed)	<b>C7035</b>	<b>19.45</b>	<b>17.68</b>
✓ Wax, Bees, 3 kilos	<b>C7037</b>	<b>194.55</b>	<b>176.86</b>

**Beeswax**



**VELCRO HOOK STARTER PADS**

✓ 200mm, Pressure Sensitive Adhesive Backing	<b>A4138</b>	<b>9.29</b>	<b>8.45</b>
✓ 230mm, Pressure Sensitive Adhesive Backing	<b>A4139</b>	<b>15.68</b>	<b>14.25</b>
✓ 250mm, Pressure Sensitive Adhesive Backing	<b>A4140</b>	<b>20.01</b>	<b>18.20</b>
✓ 280mm, Pressure Sensitive Adhesive Backing	<b>A4141</b>	<b>26.40</b>	<b>24.00</b>
✓ 300mm, Pressure Sensitive Adhesive Backing	<b>A4142</b>	<b>29.70</b>	<b>27.00</b>
✓ 350mm, Pressure Sensitive Adhesive Backing	<b>A4143</b>	<b>33.53</b>	<b>30.48</b>

**ABRASIVE DISCS - VELCRO BACKED**

✓ 10 discs, 250mm, 40grit	<b>D3315</b>	<b>43.80</b>	<b>39.82</b>
✓ 10 discs, 250mm, 60grit	<b>D3316</b>	<b>39.60</b>	<b>36.00</b>
✓ 10 discs, 250mm, 80grit	<b>D3317</b>	<b>38.40</b>	<b>34.91</b>
✓ 10 discs, 250mm, 120grit & finer	<b>D3318</b>	<b>38.40</b>	<b>34.91</b>
✓ 10 discs, 300mm, 40grit	<b>D3323</b>	<b>57.60</b>	<b>52.36</b>
✓ 10 discs, 300mm, 60grit	<b>D3324</b>	<b>55.60</b>	<b>50.55</b>
✓ 10 discs, 300mm, 80grit	<b>D3325</b>	<b>53.20</b>	<b>48.36</b>
✓ 10 discs, 300mm, 120grit & finer	<b>D3326</b>	<b>54.20</b>	<b>49.27</b>
✓ 10 discs, 350mm, 40grit	<b>D3331</b>	<b>83.20</b>	<b>75.64</b>
✓ 10 discs, 350mm, 60grit	<b>D3332</b>	<b>80.40</b>	<b>73.09</b>
✓ 10 discs, 350mm, 80grit	<b>D3333</b>	<b>77.40</b>	<b>70.36</b>
✓ 10 discs, 350mm, 120grit & finer	<b>D3334</b>	<b>78.80</b>	<b>71.64</b>



**PLAIN CLOTH BACK DISCS**

✓ Disc, Abrasive, Cloth Back, 10 discs, 350mm, 60grit	<b>D3380</b>	<b>127.05</b>	<b>115.50</b>
---	--------------	---------------	---------------

## BOBBIN SANDER SLEEVES

We can supply for any machine in a range of grits. Minimum orders apply - please email or call.

✓ 20mm x 115mm, 60 grit, (7 pcs)	<b>D3976</b>	<b>56.56</b>	<b>51.42</b>
✓ 20mm x 115mm, 80 grit, (7 pcs)	<b>D3978</b>	<b>52.36</b>	<b>47.60</b>
✓ 25.4mm x 115mm, 60 grit, (7 pcs)	<b>D3970</b>	<b>62.72</b>	<b>57.02</b>
✓ 25.4mm x 115mm, 80 grit, (7 pcs)	<b>D3973</b>	<b>58.10</b>	<b>52.82</b>
✓ 38mm x 115mm, 60 grit, (7 pcs)	<b>D3971</b>	<b>69.30</b>	<b>63.00</b>
✓ 38mm x 115mm, 80 grit, (7 pcs)	<b>D3974</b>	<b>64.54</b>	<b>58.67</b>
✓ 50.8mm x 115mm, 60 grit, (7 pcs)	<b>D3972</b>	<b>83.02</b>	<b>75.47</b>
✓ 50.8mm x 115mm, 80 grit, (7 pcs)	<b>D3975</b>	<b>76.86</b>	<b>69.87</b>
✓ 76.2mm x 115mm, 60 grit, (7 pcs)	<b>D3977</b>	<b>112.42</b>	<b>102.20</b>
✓ 76.2mm x 115mm, 80 grit, (7 pcs)	<b>D3979</b>	<b>104.16</b>	<b>94.69</b>
✓ 5/8 in diam. x 6 in long, 60 grit, 10 pieces	<b>D3980</b>	<b>50.94</b>	<b>46.31</b>
✓ 5/8 in diam. x 6 in long, 80 grit, 10 pieces	<b>D3981</b>	<b>50.94</b>	<b>46.31</b>
✓ 5/8 in diam. x 6 in long, 120 grit, 10 pieces	<b>D3982</b>	<b>50.94</b>	<b>46.31</b>
✓ 5/8 in diam. x 6 in long, 150 grit, 10 pieces	<b>D3983</b>	<b>50.94</b>	<b>46.31</b>
✓ 1 1/2 in diam. x 6 in long, 60 grit, 10 pieces	<b>D3985</b>	<b>70.02</b>	<b>63.65</b>
✓ 1 1/2 in diam. x 6 in long, 80 grit, 10 pieces	<b>D3986</b>	<b>70.02</b>	<b>63.65</b>
✓ 1 1/2 in diam. x 6 in long, 120 grit, 10 pieces	<b>D3987</b>	<b>70.02</b>	<b>63.65</b>
✓ 1 1/2 in diam. x 6 in long, 150 grit, 10 pieces	<b>D3988</b>	<b>70.02</b>	<b>63.65</b>
✓ 2 in diam. x 6 in long, 60 grit, 10 pieces	<b>D3990</b>	<b>83.52</b>	<b>75.93</b>
✓ 2 in diam. x 6 in long, 80 grit, 10 pieces	<b>D3991</b>	<b>83.52</b>	<b>75.93</b>
✓ 2 in diam. x 6 in long, 120 grit, 10 pieces	<b>D3992</b>	<b>83.52</b>	<b>75.93</b>
✓ 2 in diam. x 6 in long, 150 grit, 10 pieces	<b>D3993</b>	<b>83.52</b>	<b>75.93</b>



## SANDING BELTS

We can supply for any machine in a range of grits

✓ Standard, 610 x 100 x 24 grit, Box of 10	<b>D4028</b>	<b>34.95</b>	<b>31.77</b>
✓ Standard, 610 x 100 x 40 grit, Box of 10	<b>D4029</b>	<b>34.95</b>	<b>31.77</b>
✓ Standard, 610 x 100 x 60 grit, Box of 10	<b>D4030</b>	<b>34.95</b>	<b>31.77</b>
✓ Standard, 610 x 100 x 80 grit, Box of 10	<b>D4031</b>	<b>34.95</b>	<b>31.77</b>
✓ Standard, 610 x 100 x 100 grit, Box of 10	<b>D4032</b>	<b>34.95</b>	<b>31.77</b>
✓ Standard, 610 x 100 x 120 grit, Box of 10	<b>D4033</b>	<b>34.95</b>	<b>31.77</b>
✓ Standard, 610 x 100 x 150 grit, Box of 10	<b>D4034</b>	<b>34.95</b>	<b>31.77</b>
✓ Standard, 610 x 100 x 180 grit, Box of 10	<b>D4035</b>	<b>34.95</b>	<b>31.77</b>
✓ Standard, 610 x 100 x 220 grit, Box of 10	<b>D4036</b>	<b>34.95</b>	<b>31.77</b>
✓ Standard, 610 x 100 x 240 grit, Box of 10	<b>D4037</b>	<b>34.95</b>	<b>31.77</b>
✓ Standard, 610 x 100 x 320 grit, Box of 10	<b>D4038</b>	<b>34.95</b>	<b>31.77</b>



## DISC CEMENT

✓ Cement, Disc, for Disc Sander cloth back pads, 500ml	<b>C0390</b>	<b>32.00</b>	<b>29.09</b>
--	--------------	--------------	--------------

## VELCRO BACKED ABRASIVE SHEETS FOR HAND FLOATS 115mm x 130mm

✓ 80grit, Box of 100	<b>D3602</b>	<b>99.61</b>	<b>90.56</b>
✓ 100grit, Box of 100	<b>D3603</b>	<b>91.63</b>	<b>83.30</b>
✓ 120grit, Box of 100	<b>D3604</b>	<b>91.63</b>	<b>83.30</b>
✓ 150grit, Box of 100	<b>D3605</b>	<b>91.63</b>	<b>83.30</b>
✓ 180grit, Box of 100	<b>D3606</b>	<b>91.63</b>	<b>83.30</b>
✓ 240grit, Box of 100	<b>D3607</b>	<b>91.63</b>	<b>83.30</b>
✓ Restorer, Abrasive Disc /Belt	<b>A4135</b>	<b>5.80</b>	<b>5.27</b>



**A4135**



## WOOD CARVING

Wood Works carries the largest and most comprehensive range of woodcarving tools in Australia. The hand forged #52 series tool from Stubai in the Austrian Tyrol are an excellent starter kit. The hand forged #55 series are a slightly longer pattern with polished flute.

	ITEM	RRP	Ex GST
✓ Chisel, Carving, Set, Boxed, Stubai, 52 Series, 6 piece	F4981	114.39	103.99
✓ Chisel, Carving, Set, Stubai, 55 Series, 6 Piece	F4990	180.66	164.24
✓ Chisel, Carving, Set, Stubai, Micro Series, 6 Piece	F4998	130.37	118.52
✓ Mallet, Carver's, 210 x 70mm & 350g - 34mm handle	T3419	49.95	45.41
✓ Screw, Carver's, 150mm x 10mm, #3506	E2180	56.75	51.59

T3419



F4981



F4990



F4998



E2180

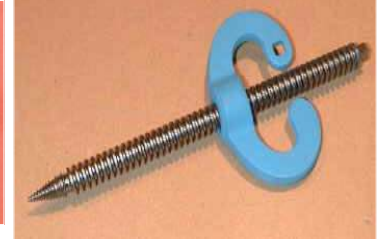

## HAND TOOLS

We supply in excess of 8,000 items from manufacturers across the world. The hand tool listing below is only a small part of the range we offer and is filtered by our long experience in dealing with schools. Please contact us for items not listed below. We refuse to market what amounts to landfill and, as a response to the extremely poor quality tools and equipment being offered to many schools and the concerns expressed to us more or less daily by teachers having to use these items, we also note the country of origin and recognised brands of the tools we sell. All our tools come with warranty and all have brands which are meaningful and manufactured by reputable makers.

### WARRINGTON (CROSS PEIN) TACK HAMMERS & DUAL PINION EGGBEATER DRILL - GERMAN MADE

✓ 125g, (4.5 oz), #2008 / 125	T4369	39.23	35.66
✓ 180g, (6oz), #2008 / 180	T4370	43.10	39.18
✓ Drill, Hand, Double Pinion, 10mm, #2551	T0495	56.45	51.32



### CABINET SCRAPERS- GERMAN AND AUSTRIAN MADE-KIRSCHEN AND STUBAI

✓ 1.2mm, 140mm x 50mm, Rectangular Heavy Gauge	T1698	5.45	4.95
✓ 1.2mm, 160mm x 60mm, Rectangular Heavy Gauge	T1699	5.95	5.41
✓ 0.6mm, 150mm x 50mm, Rectangular	T1700	7.15	6.50
✓ 0.8mm, 150mm x 50mm, Rectangular	T1701	7.15	6.50
✓ 0.8mm Goose Neck	T1702	9.95	9.04
✓ 0.8mm, 150mm x 50mm, Concave/Convex	T1703	8.19	7.45
✓ Burnisher, Round, 120mm	T1711	16.95	15.41

T1698 - T1701

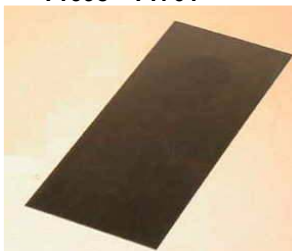

T1702



T1703



T1711



**COPING SAWS - GERMAN MADE - BOKER**

- ✓ Saw, Coping, Boker, #160
- ✓ Blades, Coping, Pinned, pkt 12, #470

ITEM	RRP	Ex GST
T1581	26.95	24.50
L1903	8.29	7.53

**T1445 & T1446**

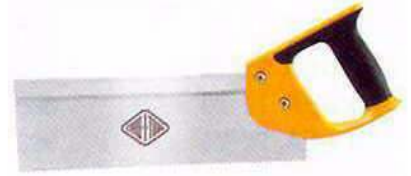

**HARD POINT TENON SAWS - BRITISH**

- ✓ 300mm, (12 inch), #S12 HP 12 12ppi

T1446	22.95	20.86
-------	-------	-------

**JAPANESE HAND SAWS - GYOKUCHO**

Japanese pull-action saws have a far superior cutting action which is within the ability of the absolute beginner wood worker. They are ideal for use in schools at all ages and replaceable blades take years to lose their edge. A Dozuki is equivalent to a western dovetail or tenon saw.

- ✓ Dozuki Noko, 0.3 x 180mm, EVA Handle, #297
- ✓ Dozuki Noko, 0.3 x 180mm, EVA Handle, #297, Box 12
- ✓ Blade, for #297

T1388	56.00	50.91
T1389	550.00	500.00
L1018	42.00	38.18

**E2525 & E2526**

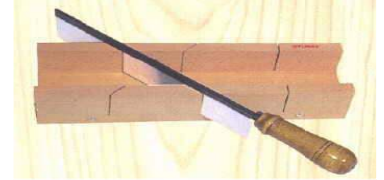

**MITRE BOXES - AUSTRIAN MADE - STUBAI**

- ✓ Box, Mitre, #345601
- ✓ Box, Mitre, and Backsaw, #345701

E2525	11.95	10.86
E2526	18.95	17.23



**GAUGES BEVELS, SQUARES & AWLS - BRITISH MADE BY MARPLES & CROWN IN SHEFFIELD**

**T7076**



**T7051**

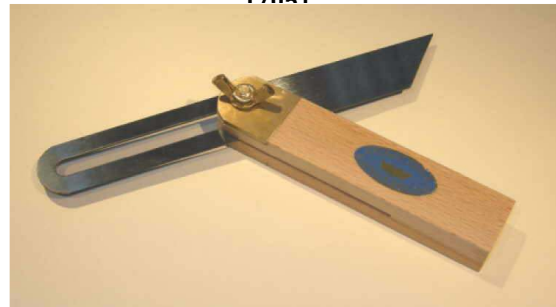

**T7210 & T7211**



**T7022**



**Marking Gauge**

- ✓ Beech, Brass Face, Plastic Screw, #136

T7449	14.17	12.88
-------	-------	-------

**Mortice & Marking Gauge**

- ✓ Beech, Wood Face, Slide Action, Plastic Screw

T7457	17.29	15.72
-------	-------	-------

**Bevels Squares & Awls**

- ✓ Bevel, Sliding, Wing Nut Lock, Beech, 190mm
- ✓ Square, Try, Beech Stock, 150mm, #120
- ✓ Square, Try, Beech Stock, 230mm, #121
- ✓ Awl, Beech, Round Blade, Screwdriver Tip 38mm blade

T7051	19.95	18.14
T7210	15.95	14.50
T7211	17.95	16.32
T7022	7.95	7.23

**RULES - GERMAN MADE - KIRSCHEN**

- ✓ Rule, Stainless Steel, 300mm / 12 inch, 1 sided

T7539	71.82	65.29
-------	-------	-------

**MARKING KNIVES, AWLS, MALLETS & SCRIBERS - BRITISH MADE - CROWN**

✓ Knife, Marking, 50mm, Right Hand, Rosewood, #112	T7321	10.42	9.47
✓ Knife, Marking, 50mm, Left Hand, Rosewood, #112A	T7322	10.42	9.47
✓ Knife, Marking, /Steel, 170mm Scribe Point & Blade	T7329	19.33	17.57
✓ Mallet, Carpenter's, 114mm, #106	T3380	19.95	18.14

#112 and #112A



T7329



T3380

**PINCERS - GERMAN MADE - BOKER. NAIL BAR - JAPANESE, THUMB SCREW SPARE**

✓ Pincers, Carpenters, 180mm, #1029 - 180	T7988	31.49	28.63
✓ Cat's Paw / Plain Pry Bar, Japanese Style, 200mm	T8026	42.90	39.00
✓ Screw, Thumb, for Marking Gauge	S0390	2.95	2.68

T7988



T8026



S0390



T3464



Allows safe starting of panel pins in hard wood and full driving in soft woods.  
Magnetic spring loaded, British made.

✓ Pusher, Brad, Rosewood handle #110XW	T3464	24.95	22.68
--	-------	-------	-------

**CHISELS - AUSTRIAN MADE - STUBAI**

**BEVEL EDGE**

Quality Austrian made bench chisels with tough poly propylene handles.

Note: There are 7 styles of bevel edge Stubai chisels available - contact us for other options.



**Stubai Series 3543**

- ✓ Set of 6, 6,10,14,18,22,26mm, Stubai, #354406 X
- ✓ 2mm, Stubai, #354302
- ✓ 4mm, Stubai, #354304
- ✓ 6mm, Stubai, (6), #354306 X
- ✓ 8mm, Stubai, #354308
- ✓ 10mm, Stubai, (6), #354310 X
- ✓ 12mm, Stubai, (4), #354312
- ✓ 14mm, Stubai, (6), #354314 X
- ✓ 16mm, Stubai, (4), #354316
- ✓ 18mm, Stubai, (6), #354318 X
- ✓ 20mm, Stubai, (4), #354320
- ✓ 22mm, Stubai, (6), #354322 X
- ✓ 24mm, Stubai, (4), #354324
- ✓ 26mm, Stubai, (6), #354326 X
- ✓ 28mm, Stubai, #354328
- ✓ 30mm, Stubai, #354330
- ✓ 32mm, Stubai, #354332
- ✓ 35mm, Stubai, #354335
- ✓ 40mm, Stubai, #354340

ITEM	RRP	Ex GST
T9347	139.00	126.36
T9449	26.95	24.50
T9450	21.83	19.85
T9451	21.83	19.85
T9452	21.83	19.85
T9453	21.83	19.85
T9454	21.83	19.85
T9455	21.83	19.85
T9456	22.61	20.55
T9457	23.60	21.45
T9458	24.01	21.83
T9459	24.95	22.68
T9460	24.95	22.68
T9461	24.95	22.68
T9462	24.95	22.68
T9463	25.47	23.15
T9464	25.47	23.15
T9465	25.99	23.63
T9466	27.14	24.67

**FIRMER - GERMAN MADE - KIRSCHEN**

**Kirschen Two Cherries Series 1021 - rectangular section, non bevel edge.**

- ✓ Chisel, Firmer, Flat Hornbeam Handle, 6mm, #1021
- ✓ Chisel, Firmer, Flat Hornbeam Handle, 10mm, #1021
- ✓ Chisel, Firmer, Flat Hornbeam Handle, 12mm, #1021
- ✓ Chisel, Firmer, Flat Hornbeam Handle, 16mm, #1021
- ✓ Chisel, Firmer, Flat Hornbeam Handle, 20mm, #1021
- ✓ Chisel, Firmer, Flat Hornbeam Handle, 26mm, #1021

T8589	33.93	30.85
T8591	34.95	31.77
T8592	35.60	32.36
T8594	34.95	31.77
T8596	41.15	37.41
T8599	48.12	43.75



**HAND PLANES**

- ✓ Plane, Block, #9 1/2, #12-020
- ✓ Plane, Block, #60 1/2, #12-060
- ✓ Plane, Block, #220, #12-220

T3000	165.50	150.45
T3001	162.44	147.67
T3002	113.86	103.50

**T3002**



**T3000 & T3001**



- ✓ Plane, #4, Smoothing, #12-004
- ✓ Plane, #5 Jack, #12-005

T3011	150.54	136.85
T3013	182.42	165.84

**T3011**



**T3013**



**SAFETY CHUCK - QUICK CHANGE KEYLESS CHUCKS AND DRILLS - MADE IN USA**

Safety chucks can be installed in any standard keyed Jacobs chuck in either stationary drill press or hand held drills. Once fitted the use of dangerous chuck keys is eliminated and drills and countersinks and any detent shank tooling can be quickly snapped into and out of the chuck.

**CHUCKS**

- ✓ Chuck, Quick Change, #40011

T0850	32.06	29.15
-------	-------	-------

T0850



**CHUCK EXTENSIONS - HEX DETENT SHANK**

Used where a longer reach is required. Can be ganged together and accept tooling.

- ✓ Quick Chuck, with 3 inch Extension, #40013
- ✓ Quick Chuck, with 6 inch Extension, #40016

T0860	28.60	26.00
T0861	31.90	29.00

T0860 & T0861



**DRILLS - HSS - HEX DETENT SHANK**

These are intergrally formed and can be sharpened but the bits are not replaceable.

- ✓ Set, 7 Piece, 1/16,3/32,1/8,5/32,3/16,7/32,1/4 inch
- ✓ Set, 13 Piece, 1/16 to 1/4 inch in 64ths
- ✓ 1/16 inch, (4/64 - 1.59mm)
- ✓ 5/64 inch, (5/64 - 1.98mm)
- ✓ 3/32 inch, (6/64 - 2.38mm)
- ✓ 7/64 inch, (7/64 - 2.78mm)
- ✓ 1/8 inch, (8/64 - 3.18mm)
- ✓ 9/64 inch, (9/64 - 3.57mm)
- ✓ 5/32 inch, (10/64 - 3.97mm)
- ✓ 11/64 inch, (11/64 - 4.37mm)
- ✓ 3/16 inch, (12/64 - 4.76mm)
- ✓ 13/64 inch, (13/64 - 5.16mm)
- ✓ 7/32 inch, (14/64 - 5.56mm)
- ✓ 15/64 inch, (15/64 - 5.95mm)
- ✓ 1/4 inch, (16/64 - 6.35mm)

T0646	50.16	45.60
T0647	94.24	85.67
T0648	6.08	5.53
T0649	6.08	5.53
T0650	6.54	5.94
T0651	6.54	5.94
T0652	6.54	5.94
T0653	6.69	6.08
T0654	6.84	6.22
T0655	6.84	6.22
T0656	7.90	7.19
T0657	6.84	6.22
T0658	9.88	8.98
T0659	6.84	6.22
T0660	12.16	11.05

T0648~T0660



**ADAPTER DRILLS - HEX DETENT SHANK**

These allow drills to be replaced when broken or dull.

- ✓ Adapter, Drill, for Quick Chuck, 1/16 inch = 4/64 inch, (1.59mm)
- ✓ Adapter, Drill, for Quick Chuck, 5/64 inch = 5/64 inch, (1.98mm)
- ✓ Adapter, Drill, for Quick Chuck, 3/32 inch = 6/64 inch, (2.37mm)
- ✓ Adapter, Drill, for Quick Chuck, 7/64 inch = 7/64 inch, (2.78mm)
- ✓ Adapter, Drill, for Quick Chuck, 1/8 inch = 8/64 inch, (3.18mm)
- ✓ Adapter, Drill, for Quick Chuck, 9/64 inch = 9/64 inch, (3.57mm)
- ✓ Adapter, Drill, for Quick Chuck, 5/32 inch = 10/64 inch, (3.97mm)
- ✓ Adapter, Drill, for Quick Chuck, 11/64 inch = 11/64 inch, (4.37mm)
- ✓ Adapter, Drill, for Quick Chuck, 3/16 inch = 12/64 inch, (4.76mm)
- ✓ Adapter, Drill, for Quick Chuck, 13/64 inch = 13/64 inch, (5.16mm)
- ✓ Adapter, Drill, for Quick Chuck, 7/32 inch = 14/64 inch, (5.56mm)
- ✓ Adapter, Drill, for Quick Chuck, 15/64 inch = 15/64 inch, (5.95mm)
- ✓ Adapter, Drill, for Quick Chuck, 1/4 inch = 16/64 inch, (6.35mm)
- ✓ Adapter, Drill, for Quick Chuck, 9/32 inch = 18/64 inch, (7.19mm)
- ✓ Adapter, Drill, for Quick Chuck, 5/16 inch = 20/64 inch, (7.94mm)
- ✓ Adapter, Drill, for Quick Chuck, 3/8 inch = 24/64 inch, (9.52mm)
- ✓ Adapter, Drill, for Quick Chuck, 1/8 inch = 8/64 inch, (3.18mm)
- ✓ Adapter, for Drills, 7 piece set, 1/16 to 1/4 inch, #40020

T0870	14.30	13.00
T0871	14.30	13.00
T0872	14.30	13.00
T0873	14.30	13.00
T0874	14.30	13.00
T0875	13.20	12.00
T0876	14.30	13.00
T0877	14.30	13.00
T0878	14.30	13.00
T0879	14.30	13.00
T0880	14.30	13.00
T0881	14.30	13.00
T0882	14.30	13.00
T0883	17.60	16.00
T0884	17.60	16.00
T0885	20.35	18.50
T0886	55.00	50.00
T0887	94.60	86.00

T0870~T0887



**COUNTERSINK/COUNTERBORE - HEX DETENT SHANK - WITH HSS DRILLS**

These cuts countersinks and with an appropriate depth stop collar plugable counterbores.

- ✓ Tool Steel, 5/64 = 5/64, (1.98mm)
- ✓ Tool Steel, 3/32 = 6/64 inch, (2.37mm)
- ✓ Tool Steel, 7/64 = 7/64 inch, (2.78mm)
- ✓ Tool Steel, 1/8 = 8/64 inch, (3.18mm)
- ✓ Tool Steel, 9/64 = 9/64 inch, (3.57mm)
- ✓ Tool Steel, 5 pce set, 5/64,3/32,7/64,1/8,9/64s
- ✓ TCT, 5/64 = 5/64, (1.98mm)
- ✓ TCT, 3/32 = 6/64 inch, (2.37mm)
- ✓ TCT, 7/64 = 7/64 inch, (2.78mm)
- ✓ TCT, 1/8 = 8/64 inch, (3.18mm)
- ✓ TCT, 9/64 = 9/64 inch, (3.57mm)
- ✓ TCT, 3/16 = 12/64 inch, (4.76mm)

T0910	22.00	20.00
T0911	22.00	20.00
T0912	22.00	20.00
T0913	22.00	20.00
T0914	22.00	20.00
T0915	88.00	80.00
T0920	57.20	52.00
T0921	57.20	52.00
T0922	49.50	45.00
T0923	49.50	45.00
T0924	49.50	45.00
T0925	49.50	45.00

T0910~T0925



**COUNTERSINKS - HEX DETENT SHANK - TOOL STEEL**

- ✓ 82 degree
- ✓ 100 degree

T0620	34.96	31.78
T0621	34.96	31.78

T0620 & T0621



**GUIDE DRILLS - HEX DETENT SHANK**

- ✓ 5/64 inch (1.98mm), #45105
- ✓ 7/64 inch (2.78mm), #45107
- ✓ 9/64 inch (3.57mm), #45109
- ✓ 11/64 inch (4.37mm), #45111
- ✓ 13/64 inch (5.16mm), #45113
- ✓ 5 piece Set, 5/64,7/64,9/64,11/64,13/64 inch
- ✓ Drill, Spare for Guide Drill, 5/64 inch
- ✓ Drill, Spare for Guide Drill, 7/64 inch
- ✓ Drill, Spare for Guide Drill, 9/64 inch
- ✓ Drill, Spare for Guide Drill, 11/64 inch
- ✓ Drill, Spare for Guide Drill, 13/64 inch

T0930	31.35	28.50
T0931	31.35	28.50
T0932	34.65	31.50
T0933	62.70	57.00
T0934	62.70	57.00
T0935	188.10	171.00
T0945	9.00	8.18
T0946	9.00	8.18
T0947	9.00	8.18
T0948	17.00	15.45
T0949	17.00	15.45

**T0930~T0949**



**STOP COLLARS - DEPTH STOP**

- ✓ 3/8 inch, for countersinks to 1/8 inch
- ✓ 1/2 inch, for 9/64 inch countersink

T0960	9.90	9.00
T0961	9.90	9.00

**T0960 & T0961**



**PLUG CUTTERS - HEX DETENT SHANK**

- ✓ Cutter, Plug, 1/4 inch (6.35mm)
- ✓ Cutter, Plug, 3/8 inch, (9.53mm)
- ✓ Cutter, Plug, 1/2 inch, (12.7mm)
- ✓ Cutter, Plug, 5/8 inch, (15.88mm)
- ✓ Cutter, Plug, 3/4 inch, (19.05mm)
- ✓ Cutter, Plug, 1 inch, (25.4mm)

T0965	31.35	28.50
T0966	37.95	34.50
T0967	44.00	40.00
T0968	50.60	46.00
T0969	72.60	66.00
T0970	93.50	85.00

**T0965~T0970**



**Cross Hole Countersinks - Australian Made**

The sweetest cutting countersink we know of and high speed steel so also useful in metalwork.

- ✓ HSS, 82deg, 4 to 10mm, #CH82-10
- ✓ HSS, 82deg, 5 to 16mm, #CH82-16
- ✓ HSS, 82deg, 8 to 20mm, #CH82-20

T0116	27.72	25.20
T0118	40.92	37.20
T0119	58.08	52.80

**T0116 - T0119**



**Woodworking Vices**

- ✓ 175mm Standard Wood Working, #60241
- ✓ 200mm Standard Wood Working, #60242
- ✓ Plain Screw, Pivot Jaw, 175mm (7 inch), #63245
- ✓ Plain Screw, 7 inch (180mm), #52PD

E2113	253.37	230.33
E2114	272.84	248.04
E2129	286.88	260.80
E2120	226.42	205.84

**E3113 & E2114**



**E2129**



**E2120**

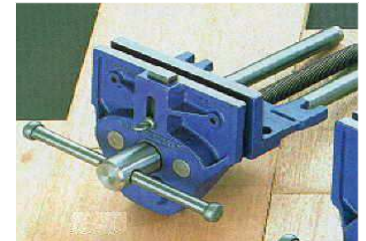

**Tapered Plug Cutters, Brad Point Wood Drills & Universal Borers**

Plug cutters cut plugs in either face or end grain, usually in matching wood, although they can be used for contrasting effect, which are often used to conceal screw heads. The use of a drill press and good work-piece clamping practice are essential when using plug cutters. Snug plug cutters are superior because they make a slightly tapered plug which fully closes the hole they are hammered into. Matching brad point or spur lip drills offer smooth cut holes and, with careful wood selection, invisible plugging. Universal borers offer a range of larger sized, smoothly cut holes for numerous project requirements. A drill press is essential.

- ✓ Cutter, Plug, Tapered, 6mm, #701860
- ✓ Cutter, Plug, Tapered, 8mm, #701861
- ✓ Cutter, Plug, Tapered, 10mm, #701862
- ✓ Cutter, Plug, Tapered, 12mm, #701863
- ✓ Cutter, Plug, Tapered, 16mm, #701864

T0170	16.12	14.65
T0171	16.88	15.35
T0172	17.14	15.58
T0173	17.55	15.95
T0174	17.99	16.35

**T0170~T0174**



## Brad Point Drills



## Universal Borers



Brad point drills are optimised for cutting smooth edge holes in wood. Universal borers are a superior alternative to forstner bits and excel at large diameter, smoothly cut, shallow holes.

### DRILLS - NATIVE BRAD POINT - step shank

✓ Drill, Brad Point, Set of 4, 4,6,8,10mm, Stubai, #300640	<b>T3528</b>	<b>16.95</b>	<b>15.41</b>
✓ Drill, Brad Point, Set of 5, 4,5,6,8,10mm, Stubai, #300650	<b>T3529</b>	<b>18.95</b>	<b>17.23</b>
✓ Drill, Brad Point, Stubai, 3mm, #300600	<b>T3530</b>	<b>4.16</b>	<b>3.78</b>
✓ Drill, Brad Point, Stubai, 4mm, #300601	<b>T3531</b>	<b>4.68</b>	<b>4.25</b>
✓ Drill, Brad Point, Stubai, 5mm, #300602	<b>T3532</b>	<b>4.94</b>	<b>4.49</b>
✓ Drill, Brad Point, Stubai, 6mm, #300603	<b>T3533</b>	<b>5.45</b>	<b>4.96</b>
✓ Drill, Brad Point, Stubai, 7mm, #300604	<b>T3534</b>	<b>6.50</b>	<b>5.91</b>
✓ Drill, Brad Point, Stubai, 8mm, #300605	<b>T3535</b>	<b>7.79</b>	<b>7.09</b>
✓ Drill, Brad Point, Stubai, 9mm, #300606	<b>T3536</b>	<b>8.73</b>	<b>7.94</b>
✓ Drill, Brad Point, Stubai, 10mm, #300607	<b>T3537</b>	<b>9.46</b>	<b>8.60</b>
✓ Drill, Brad Point, Stubai, Stepped Shank, 11mm	<b>T3538</b>	<b>14.15</b>	<b>12.86</b>
✓ Drill, Brad Point, Stubai, Stepped Shank, 12mm	<b>T3539</b>	<b>15.58</b>	<b>14.16</b>
✓ Drill, Brad Point, Stubai, Stepped Shank, 13mm	<b>T3540</b>	<b>19.90</b>	<b>18.09</b>
✓ Drill, Brad Point, Stubai, Stepped Shank, 14mm	<b>T3541</b>	<b>21.37</b>	<b>19.43</b>
✓ Drill, Brad Point, Stubai, Stepped Shank, 15mm	<b>T3542</b>	<b>23.02</b>	<b>20.93</b>
✓ Drill, Brad Point, Stubai, Stepped Shank, 16mm	<b>T3543</b>	<b>24.36</b>	<b>22.14</b>
✓ Drill, Brad Point, Stubai, Stepped Shank, 18mm	<b>T3544</b>	<b>29.98</b>	<b>27.26</b>
✓ Drill, Brad Point, Stubai, Stepped Shank, 20mm	<b>T3545</b>	<b>33.75</b>	<b>30.68</b>
✓ Drill, Brad Point, Stubai, Stepped Shank, 22mm	<b>T3546</b>	<b>37.56</b>	<b>34.14</b>
✓ Drill, Brad Point, Stubai, Stepped Shank, 24mm	<b>T3547</b>	<b>43.22</b>	<b>39.29</b>
✓ Drill, Brad Point, Stubai, Stepped Shank, 26mm	<b>T3548</b>	<b>54.13</b>	<b>49.21</b>
✓ Drill, Brad Point, Stubai, Stepped Shank, 28mm	<b>T3549</b>	<b>59.49</b>	<b>54.08</b>
✓ Borer, Universal, 12mm, #308504	<b>T0323</b>	<b>19.56</b>	<b>17.78</b>
✓ Borer, Universal, 13mm, #308505	<b>T0324</b>	<b>20.68</b>	<b>18.80</b>
✓ Borer, Universal, 14mm, #308506	<b>T0325</b>	<b>21.81</b>	<b>19.82</b>
✓ Borer, Universal, 15mm, #308507	<b>T0326</b>	<b>21.94</b>	<b>19.94</b>
✓ Borer, Universal, 16mm, #308508	<b>T0327</b>	<b>22.80</b>	<b>20.73</b>
✓ Borer, Universal, 18mm, #308509	<b>T0328</b>	<b>23.45</b>	<b>21.32</b>
✓ Borer, Universal, 20mm, #308510	<b>T0329</b>	<b>24.66</b>	<b>22.42</b>
✓ Borer, Universal, 22mm, #308511	<b>T0330</b>	<b>25.61</b>	<b>23.29</b>
✓ Borer, Universal, 24mm, #308512	<b>T0331</b>	<b>27.73</b>	<b>25.21</b>
✓ Borer, Universal, 25mm, #308513	<b>T0332</b>	<b>27.86</b>	<b>25.33</b>
✓ Borer, Universal, 26mm, #308514	<b>T0334</b>	<b>29.12</b>	<b>26.47</b>
✓ Borer, Universal, 28mm, #308515	<b>T0335</b>	<b>30.98</b>	<b>28.16</b>
✓ Borer, Universal, 30mm, #308516	<b>T0336</b>	<b>32.36</b>	<b>29.42</b>
✓ Borer, Universal, 32mm, #308517	<b>T0337</b>	<b>36.04</b>	<b>32.76</b>
✓ Borer, Universal, 34mm, #308518	<b>T0338</b>	<b>39.42</b>	<b>35.83</b>
✓ Borer, Universal, 35mm, #308519	<b>T0339</b>	<b>40.28</b>	<b>36.62</b>
✓ Borer, Universal, 36mm, #308520	<b>T0340</b>	<b>41.58</b>	<b>37.80</b>
✓ Borer, Universal, 38mm, #308521	<b>T0341</b>	<b>44.26</b>	<b>40.24</b>
✓ Borer, Universal, 40mm, #308522	<b>T0342</b>	<b>46.47</b>	<b>42.24</b>
✓ Borer, Universal, 45mm, #308523	<b>T0343</b>	<b>56.77</b>	<b>51.61</b>
✓ Borer, Universal, 50mm, #308524	<b>T0344</b>	<b>67.06</b>	<b>60.97</b>

## Repackaging, Measuring & Decanting Supplies

Our beakers, jugs and funnels are high quality Italian made lab ware  
Why should the science guys have all the fun?. Pipettes and cylinders  
for accurate measuring

### Polyethelene Bottles

- ✓ 250ml, with Resealable Witches Cap, 5 pcs
- ✓ 500ml, with Resealable Witches Cap, 4 pcs
- ✓ 1 litre, with Resealable Witches Cap, 3 pcs

- ✓ 250ml, with Cap, 5 pcs
- ✓ 500ml, with Cap, 4 pcs
- ✓ 1 litre, with Cap, 3 pcs

### PLastic Pots

- ✓ Jar, Cosmetic, 250ml with lid, 5 pcs

### Polyethelene Plastic Jerry Cans - Dangerous Goods Rated

- ✓ Bottle, Polyethelene, 1 litre, with DG Cap, 3 pcs

### Funnels

- ✓ General Purpose, High Density Polyethelne, 100mm
- ✓ General Purpose, High Density Polyethelene, 120mm
- ✓ General Purpose, High Density Polyethelene, 140mm
- ✓ General Purpose, High Density Polyethelene, 180mm
- ✓ General Purpose, High Density Polyethelene, 220mm
- ✓ General Purpose, High Density Polyethelene, 280mm

- ✓ Powder/Liquid, Large Mouth, Polypropolene, 100mm
- ✓ Powder/Liquid, Large Mouth, Polypropolene, 120mm
- ✓ Powder/Liquid, Large Mouth, Polypropolene, 150mm

### Graduated Wide Neck Storage Bottles - Round

- ✓ Bottle, Graduated, Wide Neck, Round 50ml, #409
- ✓ Bottle, Graduated, Wide Neck, Round 100ml, #409
- ✓ Bottle, Graduated, Wide Neck, Round 250ml, #410
- ✓ Bottle, Graduated, Wide Neck, Round 500ml, #411
- ✓ Bottle, Graduated, Wide Neck, Round,1000ml, #412
- ✓ Bottle, Graduated, Wide Neck, Round, 2000ml, #413

### Graduated Wide Neck Storage Bottles - Square

- ✓ Bottle, Graduated, Wide Neck, Square, 50ml, #609
- ✓ Bottle, Graduated, Wide Neck, Square, 100ml, #610
- ✓ Bottle, Graduated, Wide Neck, Square, 250ml, #611
- ✓ Bottle, Graduated, Wide Neck, Square, 500ml, #612
- ✓ Bottle, Graduated, Wide Neck, Square, 1000ml, #613
- ✓ Bottle, Graduated, Wide Neck, Square, 2000ml, #614

### Jars with Cap

- ✓ Jar, with Cap, High Density Polyethylene, 70 ml
- ✓ Jar, with Cap, High Density Polyethylene, 120 ml
- ✓ Jar, with Cap, High Density Polyethylene, 250 ml
- ✓ Jar, with Cap, High Density Polyethylene, 500 ml
- ✓ Jar, with Cap, High Density Polyethylene, 1000 ml
- ✓ Jar, with Cap, High Density Polyethylene, 2000 ml

### Wash Bottles

- ✓ Wide Mouth, Polyethylene, 250 ml, 04 Blue, #1637
- ✓ Wide Mouth, Polyethylene, 250 ml, 06 Yellow, #1637
- ✓ Wide Mouth, Polyethylene, 250 ml, 10 Red, #1637

C9000



C9000	18.18	16.53
C9001	14.61	13.29
C9002	17.65	16.04

C9010	14.07	12.79
C9011	11.88	10.80
C9012	14.91	13.55

C9015



C9015	14.15	12.86
-------	-------	-------

C9048



C9095



C9048	15.36	13.96
-------	-------	-------

C9095	3.22	2.92
C9096	4.02	3.65
C9097	6.37	5.79
C9098	11.73	10.66
C9099	16.08	14.62
C9100	20.77	18.88

C9103

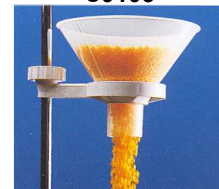

C9103	8.04	7.31
C9104	8.71	7.92
C9105	11.39	10.35

C9121

C9131



C9121	3.36	3.05
C9122	3.78	3.44
C9123	4.50	4.09
C9124	4.95	4.50
C9125	6.60	6.00
C9126	13.20	12.00

C9144

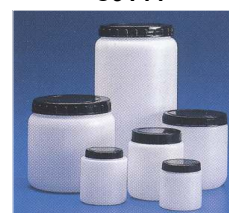

C9131	3.99	3.63
C9132	4.14	3.76
C9133	4.65	4.23
C9134	5.70	5.18
C9135	6.90	6.27
C9136	12.60	11.45

C9152



C9144	3.14	2.85
C9145	3.47	3.15
C9146	3.30	3.00
C9147	3.90	3.55
C9148	4.20	3.82
C9149	6.00	5.45

C9152	6.95	6.32
C9153	6.95	6.32
C9154	6.95	6.32

**Beakers - Graduated**

- ✓ Polypropylene, 50 ml, #1802
- ✓ Polypropylene, 100 ml, #1803
- ✓ Polypropylene, 250 ml, #1805
- ✓ Polypropylene, 500 ml, #1806
- ✓ Polypropylene, 1000 ml, #1808

- ✓ Polypropylene, Blue Graduations, 25 ml, #1821
- ✓ Polypropylene, Blue Graduations, 100 ml, #1823
- ✓ Polypropylene, Blue Graduations, 500 ml, #1825
- ✓ Polypropylene, Blue Graduations, 1000 ml, #1826
- ✓ Polypropylene, Blue Graduations, 3000 ml, #818

**Jugs**

- ✓ Measuring, Polypropylene, Squat Profile, 500 ml
- ✓ Measuring, Polypropylene, Squat Profile, 1000 ml
- ✓ Measuring, Polypropylene, Squat Profile, 2000 ml
- ✓ Measuring, Polypropylene, Squat Profile, 3000 ml
- ✓ Measuring, Polypropylene, Squat Profile, 5000 ml

- ✓ Measuring, Polypropylene, Tall Profile, 250 ml
- ✓ Measuring, Polypropylene, Tall Profile, 500 ml
- ✓ Measuring, Polypropylene, Tall Profile, 1000 ml
- ✓ Measuring, Polypropylene, Tall Profile, 2000 ml
- ✓ Measuring, Polypropylene, Tall Profile, 3000 ml

**Trays**

- ✓ Tray, Deep, ABS, 253 x 353 x 41 mm, #5707
- ✓ Tray, Deep, ABS, 252 x 252 x 42 mm, #5708
- ✓ Tray, Deep, ABS, 252 x 352 x 81 mm, #5711
- ✓ Tray, Deep, ABS, 252 x 252 x 82 mm, #5712

- ✓ Tray, Deep, PVC, 150 x 200 x 45 mm, #280
- ✓ Tray, Deep, PVC, 200 x 250 x 60 mm, #281
- ✓ Tray, Deep, PVC, 260 x 320 x 70 mm, #282
- ✓ Tray, Deep, PVC, 300 x 350 x 80 mm, #283

- ✓ Pipette, Dropping, Bellows Type, 1.5ml, 10 pieces
- ✓ Pipette, Dropping, Bellows Type, 5.0ml, 10 pieces

- ✓ Rod, Stirring, Polypropylene, 244mm, 10 pcs

- ✓ Capacity 10ml, Grads. at 2ml, 13.5mm x 140mm
- ✓ Capacity 25ml, Grads. at 5ml, 18.0mm x 195mm
- ✓ Capacity 50ml, Grads. at 10ml, 25.5mm x 199mm
- ✓ Capacity 100ml, Grads. at 10ml, 30.5mm x 249mm
- ✓ Capacity 500ml, Grads. at 50ml, 55.0mm x 361mm
- ✓ Capacity 1000ml, Grads. at 100ml, 66.0mm x 439mm

**Drum Tap**

- ✓ Tap, for threaded Drums, 3/4 inch BSP, #375

C9161	4.46	4.05
C9162	5.28	4.80
C9163	5.85	5.32
C9164	9.00	8.18
C9165	15.75	14.32

C9167	4.29	3.90
C9168	5.45	4.95
C9169	9.75	8.86
C9170	18.00	16.36
C9171	43.50	39.55

C9172	11.06	10.05
C9173	12.44	11.31
C9174	16.75	15.23
C9175	25.13	22.84
C9176	37.69	34.26

C9180	15.66	14.24
C9181	17.50	15.91
C9182	20.10	18.27
C9183	46.90	42.64
C9184	49.58	45.07

C9190	33.75	30.68
C9191	24.38	22.16
C9192	43.13	39.20
C9193	29.06	26.42

C9200	23.93	21.75
C9201	34.65	31.50
C9202	54.45	49.50
C9203	69.30	63.00

C9214	6.50	5.91
C9215	6.90	6.27

C9220	19.80	18.00
-------	-------	-------

C9225	7.80	7.09
C9226	9.00	8.18
C9227	9.00	8.18
C9228	10.20	9.27
C9229	21.60	19.64
C9230	40.80	37.09

C9250	19.00	17.27
-------	-------	-------

**C9161**



**C9167**



**C9220**

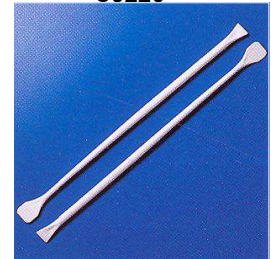

**C9214**



**C9225**



**C9172**

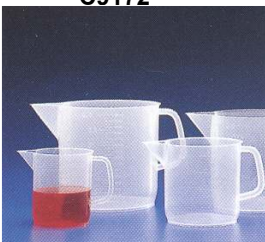

**C9180**

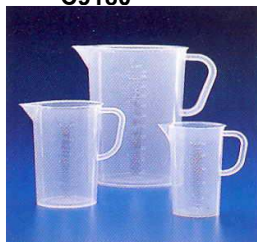

**C9190**

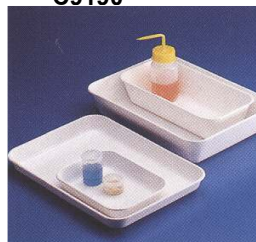

**C9200**



**C9250**

