

CATALOGUE NOW ON-LINE

ver 41 23/09/2016

For the latest version of this catalogue go to our website at www.thewoodworks.com.au
Click on the Home Page link to the Catalogue PDF's

SCOPE OF THIS CATALOGUE

We sell in excess of 8,000 products. This catalogue lists a smaller selection of items which have proven popular with schools over many years. For other items please contact us or search our website at www.thewoodworks.com.au.

ACCOUNTS

We offer immediate terms to any Australian school. No account opening procedures are needed. All we ask is that orders are on official school letterhead and have an Order Number.

FIXED WRITTEN QUOTES

To speed up your admin time we can supply you with a written quote for any of our items.

HEGNER MACHINES - SALES & SERVICE

We are very proud of the service record of our Hegner machines many of which are still performing as new after 25 years in Australian schools. We can use a metropolitan or national courier service to ship machines back to us for evaluation of you wish. We will provide a repair quote and advise the current replacement cost of the machine to assist with your repair decision.

We offer service in-situ in schools in most of suburban Sydney.

For schools outside this region we can arrange a courier to pick up your machine and ship it to us.

Alternatively we sell Hegner spare parts for schools who wish to carry out their own servicing.

If you need machines evaluated for repair or wish to arrange service use the hotline below.

FOR SERVICE CALL (02) 9979 7797

INDEX

Index	1	Pen Making	18
Scroll Saws & Accessories	2	Pepper Mill Making	19
Scroll Saw Blades	4	Toy Wheel Cutters	19
Decorative Jointing	6	Clock Making	19
Joint Genie Doweling	6	Consumables & Finishes	21
Vacuums	7	Putty Bricks	22
Plastics Strip Heaters	7	Shellac	22
Sanding Machines	7	Tung Oil	23
Bench Plane Spares	8	Beeswax	23
Turning Tools	9	Abrasive Backing Pads & Discs	23
Sharpening	10	Disc Cement	23
Pyrography	11	Carving	24
Pinewood and Plywood	12	Hand Tools	24
Project Hardware	13	Saws & Layout Tools	25
Threaded Inserts	13	Chisels	27
Hinges, Screws & Pins	14	Planes	27
Box & Cabinet Hardware	16	Plug Cutters	31
Escutcheon Pins	16	Wood Drills	31
CD & DVD Racks	18	Repackaging	32

For complete data sheets and more information on all products in this catalogue search using the ITEM CODE in the SEARCH box on the HOME PAGE at www.thewoodworks.com.au

SCROLL SAWING - HEGNER - GERMANY

For a detailed discussion about Hegner scroll saws see our dedicated companion site at www.scrollsaws.com.au

The Multicut 1 is our best selling quality scroll saw with an excellent service record and with thousands in use in Australian schools. A quality scroll saw is undoubtedly the safest powered wood saw available for use in schools. Statistically the very small risk profile of scroll saws suggests eye injury from broken blade parts and being hurt by machines falling off benches exceed the minimal risk of being cut by the blade. Hegner scroll saws can be bolted to the bench and the patented blade retaining system greatly minimises risk from blade fragments. Despite this we still suggest eye protection be worn at all times.

The Multicut 1 is available in either single or variable speed models. Blade guards and work hold down arms are available accessories.

Variable speed is factory fitted and must be specified at order time. Note that Hegner scroll saws use pinless blades of which there are numerous patterns and sizes to enable working with the widest variety of materials.

Other scroll saw make use of pinned blades which are more expensive, available in only 3 or 4 patterns and may be limited to wood.

The patented Hegner blade clamp arrangement contains broken blades and minimises risks from pieces of blade being thrown about.

These machines are fully supported with spare parts and maintenance across Australia. We routinely service machines more than 25 years old which are still in excellent functioning condition.

Hegner Multicut 1



Hegner Multicut 2S



- ✓ Saw, Scroll, Multicut 1, single speed
- ✓ Saw, Scroll, Multicut 1, vari speed
- ✓ Saw, Scroll, Multicut-2S, single speed
- ✓ Saw, Scroll, Multicut-2S, vari speed
- ✓ Saw, Scroll, Multicut-SE, vari speed

ITEM	RRP	Ex GST
M0239	995.00	904.55
M0240	1,395.00	1,268.18
M0241	1,590.00	1,445.45
M0242	1,995.00	1,813.64
M0243	2,395.00	2,177.27

POPULAR SPARES, ACCESSORIES & UPGRADES

- ✓ Assembly, Tension Rod with Quick Release function
- ✓ Assembly, Joint hose, for M1
- ✓ Assembly, Joint hose, for M2S / SE / Quick
- ✓ Bracket, Retaining, for Dust Trumpet
- ✓ Arm, Hold Down for Multicut 1 - WITHOUT GUARD
- ✓ Arm, Hold Down for Multicut 2S - WITHOUT GUARD
- ✓ Arm, Hold Down for Multicut 1 - WITH BLADE GUARD
- ✓ Arm, Hold Down for Multicut 2S - WITH BLADE GUARD
- ✓ Guard, Blade, for use with Multicut Hold Down Arm
- ✓ Part, Multicut 1, #023, Clamp, Blade
- ✓ Clamp, Quick Release, for Inside Sawing
- ✓ Key, Blade Fitting, for Hegner Blade Clamps
- ✓ Switch, Foot, for M1 / M2 / SE / Quick
- ✓ Lamp, Machine, for Multicut 1 (Screw cap lampholder)
- ✓ Bracket, for Work Lamp, for M1 C Frame
- ✓ Bracket, for Work Lamp, for M2S, SE & Quick C Frame

S1001A	99.00	90.00
S6914	73.27	66.61
S6916	77.31	70.28
S6905A	22.50	20.45
A7050	121.00	110.00
A7051	121.00	110.00
A7060	132.95	120.86
A7061	132.95	120.86
A7040	34.95	31.77
S1014	19.95	18.14
S6845	52.73	47.94
S0977	17.95	16.32
A7070	149.95	136.32
A7072	69.95	63.59
A7074	28.75	26.14
A7075	28.75	26.14

- Introduces quick release function
- Improved dust collection
- Improved dust collection
- Protects dust trumpet from damage
- Holds work on table while cutting
- Holds work on table while cutting
- Supports guard & holds work on table
- Supports guard & holds work on table
- Guard - screws onto hold down arm
- Spare standard blade clamp
- Assists with pierced work
- Spare tightening key
- Allows hands free stop start
- Improves work station lighting
- Factory made bracket for machine
- Factory made bracket for machine

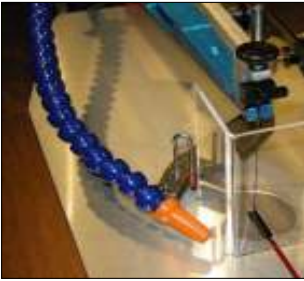
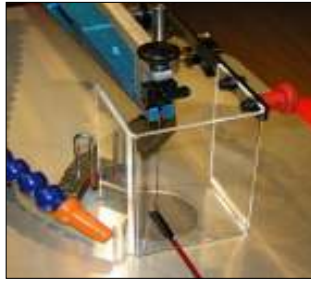
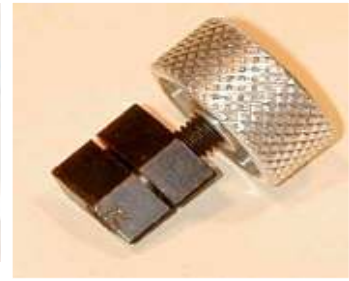
S6914 & S6916 Jointhrose**A7040 Blade guard****A7050 Hold Down****S6845 Quick Release****S0977 Key****A7070 Footswitch****A7072 Lamp****A7074 & S1001A****MULTICUT SPECIFICATIONS****Models 1 and 1e**

Shipping Weight	20 kg
Machine weight	16 kg
Warranty	3 years
Length	520mm (20 inches)
Width	270mm (11 inches)
Throat	365mm (14 inches)
Max Cut	50mm (2 inches)
Blades	Pinless 130 mm (5 inch)
Table	Machined alloy
Table size	435mm x 230mm (17" x 9")
Table tilt	0~45 degrees
Quick Tension Release	Yes at Rear
Quick Blade Clamp	No (accessory)
Indicative Noise At Idle	64.1 dB(A)
Indicative Noise Machining	74.5 dB(A)
Dust management	Dual - bellows blower & vacuum port
Stroke	Two options - 12 & 18mm
Ex Factory Stroke Setting	18mm
Speed Fixed (Model 1)	1400 spm
Speed Variable (Model 1e)	400~1400 spm
Motor	100Watts (230v, 50Hz, AC)
Motor Type (Model 1)	TEFC Cap start continuous duty
Motor Type (Model 1e)	TEFC VS drive continuous duty
Motor rating	Continuous
Indicative Capacities	
Soft Wood	50mm
Hard Wood	40mm
Alloy, Copper, Brass	5mm
Hard plastics, perspex	15mm
Polyurethane foam	50mm

Models 2S and 2Se

Shipping Weight	22 kg
Machine Weight	19kg
Warranty	3 years
Length	610mm (24 inches)
Width	280mm (11 inches)
Throat	460mm (18 inches)
Max Cut	65mm (2 1/2 inches)
Blades	Pinless 130 mm (5 inch)
Table 2S & 2Se	Machined alloy
Table size	435mm x 230mm (17" x 9")
Table tilt	-12 ~ +45 degrees
Quick Arm Tension Release	Yes at Front
Quick Blade Clamp	Yes
Indicative Noise At Idle	64.1 dB(A)
Indicative Noise Machining	74.5 dB(A)
Dust management	Dual - bellows blower & vacuum
Stroke	Two options - 12 & 19mm
Ex Factory Stroke Setting	19mm
Speed Fixed (Model 2S)	1400 spm
Speed variable (Model 2Se)	400~1400 spm
Motor	100Watts (230v, 50Hz, AC)
Motor Type (Model 2S)	TEFC Cap start contin. duty
Motor Type (Model 2Se)	TEFC VS drive contin. duty
Motor rating	Continuous
Indicative Capacities	
Soft Wood	65mm
Hard Wood	50mm
Alloy, Copper	5mm
Brass, Silver	10mm
Iron soft steel	8mm
Hard plastics, perspex	15mm
Polyurethane foam	65mm

BLADES - FOR SCROLL AND COPING SAWS

PEBECO GENERAL PURPOSE, 130mm (Note: 1 gross = 12 dozen)

General purpose blade for wood, plastics etc.	ITEM	RRP	Ex GST
✓ 1doz, #3, #180, PEBECO	L1404	11.90	10.82
✓ 1doz, #5, #180, PEBECO	L1406	11.90	10.82
✓ 1doz, #7, #180, PEBECO	L1408	11.62	10.56
✓ 1doz, #9, #180, PEBECO	L1410	12.64	11.50
✓ 1doz, #14, #180, PEBECO	L1413	13.25	12.05
✓ 1gross, #3, #180, PEBECO	L1433	95.35	86.68
✓ 1gross, #5, #180, PEBECO	L1435	95.35	86.68
✓ 1gross, #7, #180, PEBECO	L1437	ERR	ERR
✓ 1gross, #9, #180, PEBECO	L1439	98.40	89.45
✓ 1gross, #14, #180, PEBECO	L1442	109.15	99.23



FIX/REVERSE ULTRA SMOOTH CUT, 130mm - (Note: 1 gross = 12 dozen)

Fix/reverse blades have some upward cutting teeth to minimise tearout on the bottom of the work

✓ 1 doz, #1, FIX/REVERSE	L1371	11.90	10.82
✓ 1doz, #5, FIX/REVERSE	L1373	11.62	10.56
✓ 1doz, #7, FIX/REVERSE	L1374	12.64	11.50
✓ 1doz, #9, FIX/REVERSE	L1375	13.25	12.05
✓ 1doz, #12, FIX/REVERSE	L1376	13.25	12.05
✓ 1gross, #1, FIX/REVERSE	L1391	88.15	80.14
✓ 1gross, #5, FIX/REVERSE	L1393	96.15	87.41
✓ 1gross, #7, FIX/REVERSE	L1394	97.12	88.29
✓ 1gross, #9, FIX/REVERSE	L1395	106.37	96.70
✓ 1gross, #12, FIX/REVERSE	L1396	116.12	105.56



TWISTER BLADES - 130mm - (Note: 1 gross = 12 dozen)

Have spirally teeth which allows cuts in any direction without rotating the work

✓ 1doz, #1, TWISTER	L1445	14.52	13.20
✓ 1doz, #3, TWISTER	L1446	14.52	13.20
✓ 1doz, #5, TWISTER	L1447	14.52	13.20
✓ 1 Gross, #1, TWISTER	L1450	109.94	99.95
✓ 1 Gross, #3, TWISTER	L1451	111.13	101.03
✓ 1 Gross, #5, TWISTER	L1452	113.66	103.33

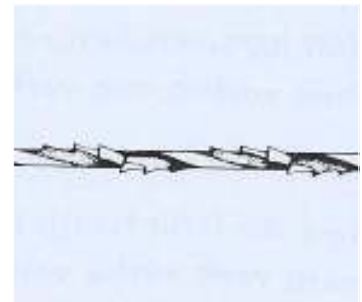

METAL CUTTING - FOR SOFT METALS (Note: 1 gross = 12 dozen)

✓ 1 doz, #1 ANTILOPE BLUE	L1535	7.31	6.64
✓ 1 doz, #3 ANTILOPE BLUE	L1536	7.31	6.64
✓ 1 doz, #5 ANTILOPE BLUE	L1537	7.31	6.64
✓ 1 doz, #7 ANTILOPE BLUE	L1538	9.73	8.84
✓ 1 doz, #9 ANTILOPE BLUE	L1539	11.77	10.70
✓ 1 gross, #1 ANTILOPE BLUE	L1550	67.46	61.33
✓ 1 gross, #3 ANTILOPE BLUE	L1551	67.46	61.33
✓ 1 gross, #5 ANTILOPE BLUE	L1552	67.46	61.33
✓ 1 gross, #7 ANTILOPE BLUE	L1553	89.77	81.61
✓ 1 gross, #9 ANTILOPE BLUE	L1554	108.62	98.74

PINNED BLADES FOR OTHER SCROLL SAW MACHINES (Note: 1 gross = 12 dozen)

✓ Blades, Scroll Saw, Pinned, 130mm 10 tpi, pkt of dozen	L1660	12.67	11.52
✓ Blades, Scroll Saw, Pinned, 130mm 15 tpi, pkt of dozen	L1661	12.67	11.52
✓ Blades, Scroll Saw, Pinned, 130mm 20 tpi, pkt of dozen	L1662	12.67	11.52
✓ Blades, Scroll Saw, Pinned, 130mm 25 tpi, pkt of dozen	L1663	12.67	11.52
✓ Blades, Scroll Saw, Pinned, 130mm 10 tpi, 1 Gross	L1670	144.31	131.19
✓ Blades, Scroll Saw, Pinned, 130mm 15 tpi, 1 Gross	L1671	144.31	131.19
✓ Blades, Scroll Saw, Pinned, 130mm 20 tpi, 1 Gross	L1672	144.31	131.19
✓ Blades, Scroll Saw, Pinned, 130mm 25 tpi, 1 Gross	L1673	144.31	131.19

Scroll Saw Blades



PINNED BLADES FOR COPING SAW FRAMES

Safety Note: Do NOT use 150mm coping blades in Hegner scroll saws. To do so risks the machine jamming at start up and catastrophic failure of the motor and/or breakage of the top arm pivot bolt because arm geometry is pushed out of limits.

✓ 165 x 0.5mm Kerf, 1.69mm pitch (15 tpi), pkt dozen	L1891	13.19	11.99
✓ 165 x 0.5mm Kerf, 1.69mm pitch (15 tpi), Grosse, (12 doz)	L1892	141.27	128.43
✓ 165 x 0.5mm Kerf, 1.27mm pitch (20 tpi), pkt dozen	L1893	13.19	11.99
✓ 165 x 0.5mm Kerf, 1.27mm pitch (20 tpi), Grosse, (12 doz)	L1894	141.27	128.43

BLADE DIMENSIONS

ITEM	COUNT	SIZE	Pins	LONG	REV. TEETH	KERF	WIDTH	TPI	PITCH mm
PEBECO 180									
L1400	1 x doz	#2/0	no	130mm		0.25	0.58	30	0.85
L1404	1 x doz	#3	no	130mm		0.34	0.77	20	1.27
L1406	1 x doz	#5	no	130mm		0.39	1.03	17	1.54
L1408	1 x doz	#7	no	130mm		0.44	1.20	14	1.81
L1410	1 x doz	#9	no	130mm		0.48	1.50	14	1.81
L1413	1 x doz	#14	no	130mm		0.55	1.90	10	2.54
L1429	12 x doz	#2/0	no	130mm		0.25	0.58	30	0.85
L1433	12 x doz	#3	no	130mm		0.34	0.77	20	1.27
L1435	12 x doz	#5	no	130mm		0.39	1.03	17	1.54
L1437	12 x doz	#7	no	130mm		0.44	1.20	14	1.81
L1439	12 x doz	#9	no	130mm		0.48	1.50	14	1.81
L1442	12 x doz	#14	no	130mm		0.55	1.90	10	2.54
FIX / REVERSE 400/R									
L1371	1 x doz	#1	no	130mm	8	0.30	0.77	15	1.69
L1373	1 x doz	#5	no	130mm	8	0.38	0.93	12	2.12
L1374	1 x doz	#7	no	130mm	8	0.42	1.10	12	2.12
L1375	1 x doz	#9	no	130mm	8	0.46	1.35	12	2.12
L1376	1 x doz	#12	no	130mm	4	0.52	1.70	8	3.18
L1391	12 x doz	#1	no	130mm	8	0.30	0.77	15	1.69
L1393	12 x doz	#5	no	130mm	8	0.38	0.93	12	2.12
L1394	12 x doz	#7	no	130mm	8	0.42	1.10	12	2.12
L1395	12 x doz	#9	no	130mm	8	0.46	1.35	12	2.12
L1396	12 x doz	#12	no	130mm	4	0.52	1.70	8	3.18
TWISTER									
L1445	1 x doz	#1	no	130mm	7	0.72	0.70		
L1446	1 x doz	#3	no	130mm	7	0.85	0.77		
L1447	1 x doz	#5	no	130mm	7	0.88	0.90		
L1450	12 x doz	#1	no	130mm	7	0.72	0.70		
L1451	12 x doz	#3	no	130mm	7	0.85	0.77		
L1452	12 x doz	#5	no	130mm	7	0.88	0.90		
METAL CUTTING									
L1535	1 x doz	#1	no	130mm		0.28	0.62	51	0.50
L1536	1 x doz	#3	no	130mm		0.36	0.75	41	0.63
L1537	1 x doz	#5	no	130mm		0.40	0.85	33	0.77
L1538	1 x doz	#7	no	130mm		0.50	1.10	28	0.91
L1539	1 x doz	#9	no	130mm		0.55	1.30	23	1.11
L1550	12 x doz	#1	no	130mm		0.28	0.62	51	0.50
L1551	12 x doz	#3	no	130mm		0.36	0.75	41	0.63
L1552	12 x doz	#5	no	130mm		0.40	0.85	33	0.77
L1553	12 x doz	#7	no	130mm		0.50	1.10	28	0.91
L1554	12 x doz	#9	no	130mm		0.55	1.30	23	1.11
PINNED SCROLLSAW BLADES									
L1660	1 x doz	10	/es	130mm		0.50	3.00	10	2.54
L1661	1 x doz	15	/es	130mm		0.50	3.00	15	1.69
L1662	1 x doz	20	/es	130mm		0.50	3.00	20	1.27
L1663	1 x doz	25	/es	130mm		0.25	2.00	25	1.02
L1670	12 x doz	10	/es	130mm		0.50	3.00	10	2.54
L1671	12 x doz	15	/es	130mm		0.50	3.00	15	1.69
L1672	12 x doz	20	/es	130mm		0.50	3.00	20	1.27
L1673	12 x doz	25	/es	130mm		0.25	2.00	25	1.02
PINNED COPING SAW									
L1891	1 x doz		/es	165mm		0.50		15	1.69
L1892	12 x doz		/es	165mm		0.50		15	1.69
L1893	1 x doz		/es	165mm		0.50		20	1.27
L1894	12 x doz		/es	165mm		0.50		20	1.27

DECORATIVE JOINTING

The ZFG Finger Jointing machine has been discontinued. Some spares remain available.

Note: From early 2015 HSS cutters are being phased out due to unavailability.

	ITEM	RRP	Ex GST
HIGH SPEED STEEL SPIRAL BITS			
✓ 4mm with 1/4 inch (6.35mm) Shank	R6145	56.95	51.77
✓ 6mm with 1/4 inch (6.35mm) Shank	R6146	56.95	51.77
✓ 12mm with 1/4 inch (6.35mm) Shank	R6149	56.95	51.77
✓ 4mm with 8mm Shank	R6151	56.95	51.77
✓ 6mm with 8mm Shank	R6152	56.95	51.77
✓ 12mm with 8mm Shank	R6155	56.95	51.77
SOLID CARBIDE			
✓ 6mm with 8mm Shank	R6165	98.15	89.23
✓ 8mm with 8mm Shank	R6166	98.15	89.23

JOINT GENIE DOWELING JIGS - BRITISH MADE

Doweling remains one of the simplest and strongest methods of joining wood and one of the safest for schools.

Given a quality adhesive and hardwood dowels, Joint Genie jigs allow the simple joining of sheet and post & rail structures for a wide variety of school woodworking. Doweling requires the use of much safer power or hand drills than equivalent methods using hand held routers.

See our site for a link to a demonstration DVD. Contact us for dowel purchase options

Craftsman 8mm



Professional 6mm or 8mm or 10mm



Multi Professional 6/8/10mm



Jobber 6mm or 8mm



✓ 'Joint Genie', Craftsmen, 8mm	E0136	282.35	256.68
✓ 'Joint Genie', Professional, 6mm	E0143	186.15	169.23
✓ 'Joint Genie', Professional, 8mm	E0144	191.35	173.95
✓ 'Joint Genie', Professional, 10mm	E0145	194.40	176.73
✓ 'Joint Genie', Multi Professional, 6mm, 8mm, 10mm	E0151	332.50	302.27
✓ 'Joint Genie', Jobber, 6mm	E0155	129.15	117.41
✓ 'Joint Genie', Jobber, 8mm	E0156	129.15	117.41

VACUUMS

HEGNER MAXIMUS UNDERBENCH VACUUM

The Hegner Maximus is the perfect machine for installations where distributed dust control is installed.

The Maximus from Hegner is a down-size, quiet vacuum with variable suction which is ideally suited to placement under work benches.

It has a master-slave feature which allows bench top machines to automatically switch the vacuum on and off.

This saves on power consumption and reduces noise in the work room. Only 62dB (A) at max power

- ✓ Vacuum/Dust Extractor, Maximus 13E
- ✓ Bag, Filter, for Hegner Maximus 13E, 10 pieces

ITEM	RRP	Ex GST
M0920	589.55	535.95
C0720	72.19	65.63

Specifications

Model	Hegner Maximus 13E
Height	405mm
Width	290mm
Depth	400mm
Weight	tba
Mains	230 volt AC, 50 Hz
Max power	1250 watts
Noise at Max power	62dB(A)
Variable suction & noise	Yes
Dust volume	13 litres
Mains cable	10 metres
Dust hose	2.5 metres
Hose swivel connection	Yes
Suction throughput	Max. 60 litres/sec
Vacuum Pressure	290 mbar
Filtration	HEPA H21
Bags	Yes, disposable (See C0720)
Accessories	Floor wand, Crevice & Furniture Brush Upholstery nozzles



**MODEL 500
MODEL 1000**



STRIP HEATERS FOR PLASTICS WORK

- ✓ 500mm Capacity, 240Volts, 200Watts, #SH 500-1
- ✓ 1000mm Capacity, 240Volts, 200Watts, #SH 1000-1

M0050	714.00	649.09
M0051	891.00	810.00

SANDING

HEGNER SANDERS

The WSM German made Hegner disc sander has a 300mm, fully guarded velcro equipped hook disc & is equipped with no-volt starting. It is fitted with an efficient dust collection port.

The HSM-300S has a tilting disc and fixed table which allows heavier pieces to be work. Digital tilt gauge is an option.

The TWS 230 table drum sander has a sanding width of 230mm and table 520mm x 320mm. Fence is optional. The TWS is the perfect companion machine for the Hegner scroll saws and finger jointers. With a fence fitted (please order as accessory) and table height perfectly adjusted it can final sand most scroll saw and box projects very safely.

The TBS 500 belt sander tilts so that the sanding platten can be either horizontal or vertical. The optional bobbin attachment fits to the belt sander. The machine has no-volt starting and excellent dust porting. (Stand illustrated but not supplied)

- ✓ Sander, Disc, 300mm, #WSM-300
- ✓ Sander, Disc, #HSM-300
- ✓ Sander, Disc, #HSM-300 S
- ✓ Sander, Drum, Hegner, #TWS230
- ✓ Sander, Drum, Belt, #TBS-500
- ✓ Sander, Bobbin, Accessory for, #TBS-500

ITEM	RRP	Ex GST
M1052	1,165.00	1,059.09
M1051	1,799.00	1,635.45
M1050	2,038.00	1,852.73
M1094	665.00	604.55
M1043	2,995.00	2,722.73
A4131	372.00	338.18

M1052



M1094



M1050



M1043



A4131



M1051



BENCH PLANE SPARE PARTS

For several years spares for Stanley planes for been only intermittently available and in many cases only in quite extensive kits. In addition to these kits we now can offer some parts to the component level for all other than Y levers, lateral adjust levers and frog clips all of which require the purchase of a full frog assembly.

Spares

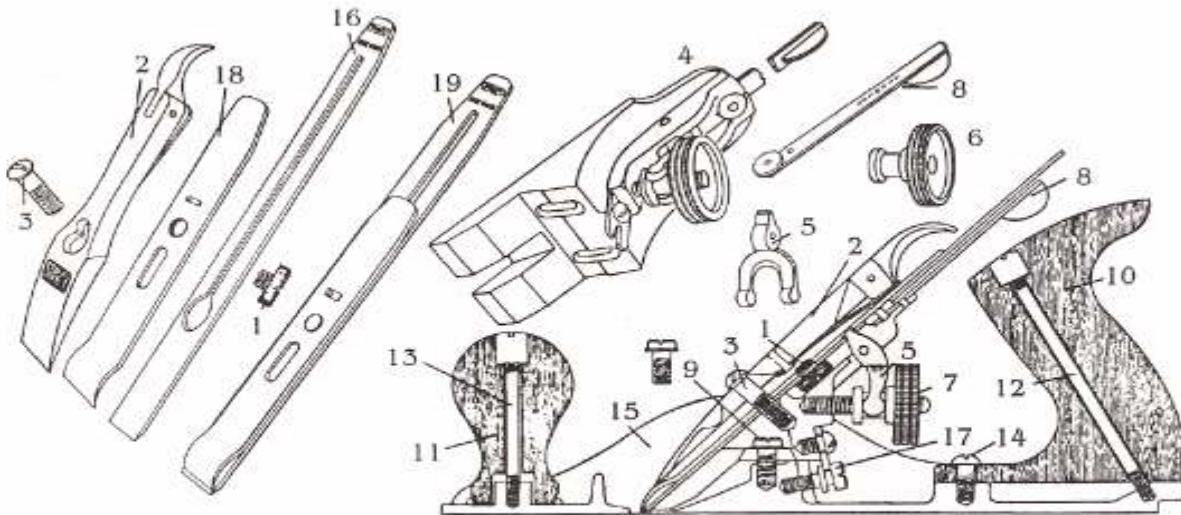

- | | | | | | | | |
|---|---------------------|----|-------------------------|----|-------------------|----|----------------------|
| 1 | Cap screw | 6 | Adjusting nut | 11 | Knob | 16 | Cutting iron |
| 2 | Lever cap | 7 | Adjusting nut screw | 12 | Handle bolt & nut | 17 | Frog adjusting screw |
| 3 | Lever cap screw | 8 | Lateral adjusting screw | 13 | Knob bolt & nut | 18 | Back iron |
| 4 | Frog complete | 9 | Frog screw | 14 | Handle screw | | |
| 5 | "Y" adjusting lever | 10 | Handle | 15 | Plan body | | |

SPARES KITS

- ✓ No: 1, Handle & Knob, for #3, #4
- ✓ No: 2, Handle & Knob, for #4 1/2, #5, #5 1/2, #6, #7
- ✓ No: 3, Bench Plane Fasteners
- ✓ No: 8, Lever Cap for #4, #5
- ✓ No: 9, Lever Cap for #4 1/2, #5 1/2, #8, #7

ITEM	RRP	Ex GST	PART
S2980	25.64	23.31	10,12,14,11,13
S2981	25.98	23.62	10,12,14,11,13
S2983	32.54	29.58	Set of Stanley & Metric.
S2987	41.50	37.73	2
S2988	68.30	62.09	2

SPARES INDIVIDUALLY - (NOTE: ALL STANLEY THREAD, VERY NEW PLANES MAY BE METRIC)

✓ Screw & Nut, Handle, #3 to #4, #P78987	S3005	6.50	5.91	12
✓ Screw & Nut, Handle, #4.5 to #7, #P78995	S3006	6.50	5.91	12
✓ Screw & Nut, Knob, #3 & #4, #P79026	S3007	6.50	5.91	13
✓ Screw & Nut, Knob, #4.5 to #7, #P79034	S3008	6.50	5.91	13
✓ Screw, Toe, #P36396	S3010	8.12	7.38	14
✓ Screw, Frog Mounting, and Washer, #P78979	S3011	4.00	3.64	9
✓ Screw, Lever Cap, #P33066	S3012	6.50	5.91	3
✓ Screw, Cap/Back Iron, #3 to #7, #P33009	S3013	6.00	5.45	1
✓ Screw, Frog Adjusting, #P32864	S3014	6.50	5.91	17
✓ Nut, Adjusting, #P34419	S3016	12.50	11.36	6
✓ Screw, Adjusting Nut, #P34427	S3017	6.00	5.45	7

P&N HIGH SPEED STEEL WOODTURNING TOOLS - P&N - AUSTRALIA

P&N tools are fabricated in Australia using Austrian high speed steel. They have many features which make them an excellent choice for school use. They are fitted with very tough Spotted Gum handles and the gouge flutes are ground extra long for extended tool life.

The skews have a fully rounded bottom edge - the 24mm skew is 8mm thick, not the usual 6mm.

Note: We supply round nose scrapers for the price of square scrapers for no extra charge

P&N SPINDLE (conventional flute)

	ITEM	RRP	Ex GST
✓ Spindle Gouge, 6mm, Handled,	T6300	70.88	64.43
✓ Spindle Gouge, 6mm, Un Handled	T6301	43.60	39.64
✓ Spindle Gouge, 8mm, Handled	T6302	73.14	66.49
✓ Spindle Gouge, 8mm, Un Handled	T6303	50.40	45.82
✓ Spindle Gouge, 10mm, Handled	T6304	88.73	80.67
✓ Spindle Gouge, 10mm, Un Handled	T6305	56.32	51.20
✓ Spindle Gouge, 12mm, Handled	T6306	92.51	84.10
✓ Spindle Gouge, 12mm, Un Handled	T6307	68.98	62.71
✓ Spindle Gouge, 16mm, Handled	T6308	116.14	105.58
✓ Spindle Gouge, 16mm, Un Handled	T6309	86.43	78.57
✓ Spindle Gouge, 19mm, Handled	T6310	128.30	116.64
✓ Spindle Gouge, 19mm, Un Handled	T6311	106.32	96.65

T6300 - T6311



P&N BOWL GOUGE (measured by bar diameter)

	ITEM	RRP	Ex GST
✓ Bowl Gouge, 6mm, Handled	T6315	72.71	66.10
✓ Bowl Gouge, 6mm, Un Handled	T6316	47.56	43.24
✓ Bowl Gouge, 8mm, Handled	T6317	76.42	69.47
✓ Bowl Gouge, 8mm, Un Handled	T6318	51.93	47.21
✓ Bowl Gouge, 10mm, Handled	T6319	91.70	83.36
✓ Bowl Gouge, 10mm, Un Handled	T6320	60.26	54.79
✓ Bowl Gouge, 12mm, Handled	T6321	87.03	79.12
✓ Bowl Gouge, 12mm, Un Handled	T6322	73.45	66.78
✓ Bowl Gouge, 16mm, Handled	T6323	113.18	102.89
✓ Bowl Gouge, 16mm, Un Handled	T6324	88.14	80.13

T6315 - T6324



P&N SUPA GOUGE (extra length flute - long & strong)

✓ Supa Gouge, 16mm, Handled	T6330	157.48	143.16
✓ Supa Gouge, 16mm, Un Handled	T6331	135.36	123.05
✓ Supa Gouge, 22mm, Handled	T6332	187.63	170.57
✓ Supa Gouge, 22mm, Un Handled	T6333	165.54	150.49

T6330 - T6333



P&N DETAIL GOUGE (shallow flute high waisted)

✓ Detail Gouge, 8mm, Handled	T6338	100.43	91.30
✓ Detail Gouge, 8mm, Un Handled	T6339	78.31	71.19
✓ Detail Gouge, 10mm, Handled	T6340	104.75	95.22
✓ Detail Gouge, 10mm, Un Handled	T6341	82.71	75.19
✓ Detail Gouge, 12mm, Handled	T6342	110.66	100.60
✓ Detail Gouge, 12mm, Un Handled	T6343	88.68	80.61
✓ Detail Gouge, 16mm, Handled	T6344	130.16	118.33
✓ Detail Gouge, 16mm, Un Handled	T6345	114.70	104.27

T6338 - T6345



P&N ROUGHING GOUGE (25 & 32 ground bar, 40mm forged)

✓ 25mm Roughing Gouge, Handled	T6350	183.57	166.88
✓ 25mm Roughing Gouge, Un Handled	T6351	161.61	146.92
✓ 32mm Roughing Gouge, Handled	T6352	238.56	216.88
✓ 32mm Roughing Gouge, Un Handled	T6353	216.35	196.68

T6350 - T6353



P&N SKEW

- ✓ Standard Skew, 12 x 6mm, Handled
- ✓ Standard Skew, 12 x 6mm, Un Handled
- ✓ Standard Skew, 18 x 6mm, Handled
- ✓ Standard Skew, 18 x 6mm, Un Handled
- ✓ Standard Skew, 24mm x 8mm, Handled
- ✓ Standard Skew, 24mm x 8mm, Un Handled
- ✓ Standard Skew, 30 x 8mm, Handled
- ✓ Standard Skew, 30 x 8mm, Un Handled

T6360	114.84	104.40
T6361	69.91	63.56
T6362	139.94	127.22
T6363	94.05	85.50
T6364	160.75	146.13
T6365	104.75	95.22
T6366	175.09	159.17
T6367	122.92	111.74

T6360 - T6367



P&N PARTING

- ✓ Standard Section Parting Tool, 3 x 12mm, Handled
- ✓ Standard Section Parting Tool, 3 x 12mm, Un Handled
- ✓ Standard Section Parting Tool, 6 x 12mm, Handled
- ✓ Standard Section Parting Tool, 6 x 12mm, Un Handled

ITEM	RRP	Ex GST
T6370	85.31	77.55
T6371	63.35	57.59
T6372	98.02	89.11
T6373	72.29	65.72

T6370 - T6373



P&N SQUARE NOSE SCRAPER

- ✓ Square Nose Scraper, 12 x 8mm, Handled
- ✓ Square Nose Scraper, 12 x 8mm, Un Handled
- ✓ Square Nose Scraper, 18 x 8mm, Handled
- ✓ Square Nose Scraper, 18 x 8mm, Un Handled
- ✓ Square Nose Scraper, 24 x 8mm, Handled
- ✓ Square Nose Scraper, 24 x 8mm, Un Handled
- ✓ Square Nose Scraper, 30 x 8mm, Handled
- ✓ Square Nose Scraper, 30 x 8mm, Un Handled

T6375	100.99	91.81
T6376	63.62	57.84
T6377	130.31	118.46
T6378	75.43	68.57
T6379	141.81	128.92
T6380	84.21	76.56
T6381	146.82	133.47
T6382	96.18	87.43

T6375 - T6382



P&N BEADING

- ✓ Beading Tool, 10 x 10mm, Handled
- ✓ Beading Tool, 10 x 10mm, Un Handled

T6385	106.04	96.40
T6386	61.27	55.70

T6385 - T6386



SHARPENING

SLOW SPEED WATER GRINDERS - SCANGRIND - DENMARK

Slow speed water grinders sharpen all carbon steel edge tools with minimal risk to the operator. Water grinders are a perfect solution for bench and carving chisels and hand plane blades. The wheel rotates slowly in a water bath making it impossible to overheat the tool. These machines are safer than high speed bench grinders and the grinding process is slower and more controllable. Item Code M0004 is supplied with a diamond honing lapping plate which allows for final honing of edges. There are accessories for assisted grinding, repeatability and additional precision - see below.

WATER GRINDERS , ACCESSORIES & SPARES

- ✓ Grinder, Water, Scan 200EK, #SC200EK
- ✓ Unit, Base, 'Startset', for Scangrind 200, #3800025
- ✓ Guide, Sliding, for Scan Grind 200, #3800026
- ✓ Jig, Grinding, Universal, for Scan 200, #3800023
- ✓ Jig, Grinding, Fingernail, for Scan 200, #3800021
- ✓ Wheel, Grinding, Scan 200mm Water Grinder, Spare

ITEM	RRP	Ex GST
M0005	559.44	508.58
A1981	104.58	95.07
A1982	81.90	74.45
A1983	78.12	71.02
A1986	104.58	95.07
S1341	164.64	149.67



A1981 + A1982



A1981 + A1982 + A1983



A1986



S1341



HIGH SPEED BENCH GRINDERS

High speed bench grinders sharpen all steel tools including high speed steel turning tools. The grinding wheels supplied with the great majority of bench grinders are suited to grinding mild steel for welding and not tool sharpening. An aluminium oxide, cool running wheel should be fitted for tool sharpening. to keep grinding wheels maintained. Our grinder is Danish made and comes with both A dressing stick, either a carborundum block or diamond point, is an essential tool.

BENCH GRINDERS, ACCESSORIES & SPARES

- ✓ Wheel, Alu.Oxide 46grit, 200mm x 25mm, Multi Bushed
- ✓ Wheel, Alu.Oxide 60grit, 200mm x 25mm, Multi Bushed
- ✓ Wheel, Alu.Oxide 80grit, 200mm x 25mm, Multi Bushed
- ✓ Wheel, Alu.Oxide 80grit, 150mm x 25mm, Multi Bushed
- ✓ Wheel, Alu.Oxide 120grit, 200mm x 25mm, Multi Bushed
- ✓ Stick, Dressing, Diamond, 0.5 carat

ITEM	RRP	Ex GST
S0027	44.12	40.11
S0028	44.12	40.11
S0029	44.12	40.11
S0030	27.43	24.94
S0031	44.12	40.11
E0001	40.75	37.05

S0027 to S0031



E0001



HAND SHARPENING EQUIPMENT

Diamond sharpening plates are now available in a range of grits which means they are a complete alternative to other sharpening and honing systems. They are very durable and do not cup after extended use.

Waterstones offer the ultimate edge however are not as durable as other stones or diamond plates and must be used with a honing guide. Stropps should be used with honing compound. Aluminium oxide wheels are the preferred wheel for tool sharpening on a high speed bench grinder. A honing guide which holds the straight edge tool at the correct angle is strongly recommended.

- ✓ Guide, Honing

ITEM	RRP	Ex GST
T0010	95.65	86.95

T0010



PYROGRAPHY (WOOD BURNING)

The Australian made Ironcore has wide acceptance in the Australian School market.

- ✓ Kit, Pyrography, Ironcore, Pokerworker, T3/54
- ✓ Handle, Ironcore Pyrography Tool, Spare
- ✓ Tips, Ironcore Pyrograph Tool, pkt 10

ITEM	RRP	Ex GST
E0121	295.00	268.18
S0600	66.00	60.00
S0621	16.95	15.41

S0600



S0621



PROJECT COMPONENTS & MATERIALS

Wood Works supplies some sizes of pre-cut plywood and pine for school projects. We supply Radiata Pine in solid wood form and Hoop Pine as plywood, both of which are fully plantation grown in Australia and are sustainably harvested. The pine is supplied fault docked which removes major knots and blemishes and is suited to many school projects. The Hoop Pine ply is a clear, pale, fine grained ply which cuts smoothly and is easily finished. It is ideal for pyrography (wood burning) projects.

Minimum orders apply. Some popular sizes are listed below. Other sizes available on request.

HOOP PINE FACED PLYWOOD

	ITEM	RRP	Ex GST
✓ Ply, Hoop Pine, A4, 295mm x 210mm x 4mm, Packs 20	W4000	please call for quote	
✓ Ply, Hoop Pine, A4, 295mm x 210mm x 6mm, Packs 40	W4001	please call for quote	
✓ Ply, Hoop Pine, A4, 295mm x 210mm x 9mm, Packs 40	W4002	please call for quote	
✓ Ply, Hoop Pine, A4, 295mm x 210mm x 12mm, Packs 40	W4003	please call for quote	
✓ Ply, Hoop Pine, A3, 395mm x 295mm x 4mm, Packs 24	W4050	please call for quote	
✓ Ply, Hoop Pine, A3, 395mm x 295mm x 6mm, Packs 24	W4051	please call for quote	
✓ Ply, Hoop Pine, A3, 395mm x 295mm x 9mm, Packs 24	W4052	please call for quote	
✓ Ply, Hoop Pine, A3, 395mm x 295mm x 12mm, Packs 24	W4053	please call for quote	
✓ Ply, Hoop Pine, 190 x 295 x 4mm, Packs of 48	W4070	please call for quote	
✓ Ply, Hoop Pine, 295 x 295 x 4mm, Packs of 32	W4071	please call for quote	
✓ Ply, Hoop Pine, 445 x 295 x 4mm, Packs of 20	W4072	please call for quote	
✓ Ply, Hoop Pine, 445 x 310 x 4mm, Bases for Trays, Packs	W4073	please call for quote	



PINE WOOD, FAULT DOCKED

	ITEM	RRP	Ex GST
✓ 42mm x 12mm -130mm long	W5140	please call for quote	
✓ 42mm x 12mm -150mm long	W5145	please call for quote	
✓ 42mm x 12mm - 210mm long	W5151	please call for quote	
✓ 42mm x 12mm - 295mm long	W5152	please call for quote	
✓ 42mm x 12mm - 381mm long	W5153	please call for quote	
✓ 140mm x 12mm - 140mm long	W5301	please call for quote	
✓ 140mm x 12mm - 210mm long	W5302	please call for quote	
✓ 140mm x 12mm - 300mm long	W5303	please call for quote	
✓ 140mm x 12mm - 400mm long	W5304	please call for quote	
✓ 140mm x 19mm - 310mm	W5460	please call for quote	
✓ 190mm x 19mm - 200mm	W5481	please call for quote	
✓ 190mm x 19mm - 295mm A4	W5482	please call for quote	
✓ 190mm x 19mm - 350mm	W5483	please call for quote	



We supply schools with pre cut and machined components for projects such as serving trays and bookends. Please contact us for your requirements.

HINGES

	ITEM	RRP	Ex GST
✓ Butt, Brass, 3/4 x 5/8 inch, with 8x2.3mm screws, pair	H0200	6.48	5.89
✓ Butt, Brass, 2 1/2 x 5/8 inch, with 8x2.3mm screws, pair	H0260	15.23	13.85
✓ Butt, Brass, 90deg 1 x 5/8 inch, with 8x2.3mm screws, pair	H0261	15.12	13.75
✓ Knuckle, Brass, 5mm, pkt 6	H0400	13.95	12.68
✓ Knuckle, Brass/Nickel Plated, 5mm, pkt 6	H0401	13.95	12.68
Hinge, Concealed Knuckle, Soss Type, Steel/Brass Plated			
✓ 8mm, pair	H0449	17.55	15.95
✓ 10mm x 11mm, pair, #ZH10	H0450	18.36	16.69
✓ 12mm x 12mm, pair, #ZH12	H0451	18.96	17.24
✓ 14mm x 16mm, pair, #ZH14	H0452	20.28	18.44
✓ 16mm x 17mm, pair, #ZH16	H0453	23.52	21.38
✓ 18mm x 18mm, pair, #ZH18	H0454	28.76	26.15
✓ 24mm x 25mm, pair, #ZH24	H0455	54.44	49.49

H0200



H0400



H0450



CUTLER'S RIVETS - SOLID BRASS, SETS OF 1 SPUR AND 1 SHEATH

✓ 6mm head x 8mm shaft, 11mm max material, 10sets	H0090	6.07	5.52
✓ 6mm head x 10mm shaft, 15mm max material, 10sets	H0091	6.84	6.22
✓ 8.5mm head x 16mm shaft, 25mm max material, 6 sets	H0092	9.37	8.52



THREADED INSERTS FOR WOOD - SOLID BRASS

- ✓ Insert, Threaded, Brass, 3mm, pair
- ✓ Insert, Threaded, Brass, 3mm, dozen
- ✓ Insert, Threaded, Brass, 4mm, pair
- ✓ Insert, Threaded, Brass, 4mm, dozen
- ✓ Insert, Threaded, Brass, 5mm, pair
- ✓ Insert, Threaded, Brass, 5mm, dozen
- ✓ Insert, Threaded, Brass, 6mm, pair
- ✓ Insert, Threaded, Brass, 6mm, dozen
- ✓ Insert, Threaded, Brass, 8mm, pair
- ✓ Insert, Threaded, Brass, 8mm, dozen
- ✓ Insert, Threaded, Brass, 1/4 inch, pair
- ✓ Insert, Threaded, Brass, 1/4 inch, dozen
- ✓ Insert, Threaded, Brass, 5/16 inch, pair
- ✓ Insert, Threaded, Brass, 5/16 inch, dozen
- ✓ Insert, Threaded, Brass, 3/8 inch, pair
- ✓ Insert, Threaded, Brass, 3/8 inch, dozen

H3900	3.85	3.50
H3901	13.85	12.59
H3902	4.06	3.69
H3903	14.62	13.29
H3914	4.13	3.76
H3915	14.88	13.53
H3904	5.36	4.87
H3905	19.29	17.54
H3906	7.23	6.57
H3907	26.01	23.65
H3908	5.54	5.04
H3909	19.94	18.13
H3910	5.54	5.04
H3911	19.94	18.13
H3912	7.23	6.57
H3913	26.01	23.65

Solid Brass



ZINC ALLOY

- ✓ FLANGED, 5mm x 1.0mm pitch, pair
- ✓ FLANGED, 5mm x 1.0mm pitch, dozen
- ✓ FLANGED, 6mm x 1.0mm pitch, pair
- ✓ FLANGED, 6mm x 1.0mm pitch, dozen
- ✓ FLANGED, 8mm x 1.25mm pitch, pair
- ✓ FLANGED, 8mm x 1.25mm pitch, dozen
- ✓ FLANGED, 10mm x 1.5mm pitch, pair
- ✓ FLANGED, 10mm x 1.5mm pitch, dozen
- ✓ FLANGED, 1/4 inch x 20tpi BSW, pair
- ✓ FLANGED, 1/4 inch x 20 tpi BSW, dozen
- ✓ FLANGED, 5/16 inch x 18tpi BSW, pair
- ✓ FLANGED, 5/16 inch x 18 tpi BSW, dozen
- ✓ UN-FLANGED, 6mm x 1.0mm pitch, pair
- ✓ UN-FLANGED, 6mm x 1.0mm pitch, dozen
- ✓ UN-FLANGED, 8mm x 1.25mm pitch, pair
- ✓ UN-FLANGED, 8mm x 1.25mm pitch, dozen
- ✓ UN-FLANGED, 5/16 inch x 18tpi BSW, pair
- ✓ UN-FLANGED, 5/16 inch x 18 tpi BSW, dozen

H3940	2.70	2.45
H3941	13.50	12.27
H3942	2.70	2.45
H3943	13.50	12.27
H3944	2.80	2.55
H3945	14.00	12.73
H3946	2.80	2.55
H3947	18.15	16.50
H3948	2.60	2.36
H3949	13.00	11.82
H3950	2.80	2.55
H3951	14.00	12.73
H3952	2.90	2.64
H3953	14.50	13.18
H3954	3.10	2.82
H3955	15.50	14.09
H3956	3.10	2.82
H3957	15.50	14.09

Zinc Alloy Flanged



Zinc Alloy Un-Flanged



BRASS BUTT HINGES - OPEN 270 DEGREES

- ✓ 2 pair, High 25mm x Long 19mm
- ✓ 100 pairs, High 25mm x Long 19mm
- ✓ 2 pair, High 38mm x Long 22mm
- ✓ 100 pairs, High 38mm x Long 22mm

ITEM	RRP	Ex GST
H0270	11.90	10.82
H0271	476.00	432.73
H0272	14.95	13.59
H0273	598.00	543.64

H0270



MICRO WOOD SCREWS - STEEL BRASS PLATED

- ✓ Screws, Brass Plated, 4mm x 1.7mm, pkt approx 100
- ✓ Screws, Brass Plated, 5mm x 2.0mm, pkt approx 100
- ✓ Screws, Brass Plated, 6mm x 1.7mm, pkt approx 100
- ✓ Screws, Brass Plated, 6mm x 2.0mm, pkt approx 100
- ✓ Screws, Brass Plated, 8mm x 2.3mm, pkt approx 100
- ✓ Screws, Brass Plated, 10mm x 2.3mm, pkt approx 100
- ✓ Screws, Brass Plated, 12mm x 2.0mm, pkt approx 100
- ✓ Screws, Brass Plated, 12mm x 2.3mm, pkt approx 100

ITEM	RRP	Ex GST
H5210	7.19	6.54
H5211	7.80	7.09
H5212	8.41	7.64
H5213	8.41	7.64
H5214	10.20	9.28
H5215	10.20	9.28
H5216	12.61	11.46
H5217	12.61	11.46

H5210



BRASS COUNTERSUNK HEAD WOOD SCREWS - SLOTTED HEAD

✓ 2 Gauge x 1/4 inch (6mm), Box 100pcs	H8300	11.98	10.89
✓ 2 Gauge x 3/8 inch (10mm), Box 100pcs	H8301	14.90	13.55
✓ 2 Gauge x 1/2 inch (12mm), Box 100pcs	H8302	14.60	13.27
✓ 2 Gauge x 3/4 inch (19mm), Box 100pcs	H8303	16.75	15.23
✓ 3 Gauge x 3/8 inch (10mm), Box 100pcs	H8305	17.80	16.18
✓ 3 Gauge x 1/2 inch (12mm), Box 100pcs	H8306	19.38	17.61
✓ 3 Gauge x 5/8 inch (16mm), Box 100pcs	H8307	15.80	14.36
✓ 3 Gauge x 3/4 inch (19mm), Box 100pcs	H8308	14.65	13.32
✓ 4 Gauge x 3/8 inch (10mm), Box 100pcs	H8310	15.45	14.05
✓ 4 Gauge x 1/2 inch (12mm), Box 100pcs	H8311	21.60	19.64
✓ 4 Gauge x 5/8 inch (16mm), Box 100pcs	H8312	15.70	14.27
✓ 4 Gauge x 3/4 inch (19mm), Box 100pcs	H8313	17.90	16.27
✓ 4 Gauge x 7/8 inch (22mm), Box 100pcs	H8314	20.40	18.55
✓ 4 Gauge x 1 1/4 inch (32mm), Box 100pcs	H8315	22.25	20.23
✓ 5 Gauge x 1/2 inch (12mm), Box 100pcs	H8317	16.75	15.23
✓ 5 Gauge x 5/8 inch (16mm), Box 100pcs	H8318	19.25	17.50
✓ 5 Gauge x 1 inch (25mm), Box 100pcs	H8319	25.88	23.52
✓ 6 Gauge x 3/8 inch (10mm), Box 100pcs	H8321	27.33	24.84
✓ 6 Gauge x 5/8 inch (16mm), Box 100pcs	H8322	25.15	22.86
✓ 6 Gauge x 3/4 inch (19mm), Box 100pcs	H8323	28.30	25.73
✓ 6 Gauge x 1 inch (25mm), Box 100pcs	H8324	39.33	35.75
✓ 6 Gauge x 1 1/4 inch (32mm), Box 100pcs	H8325	41.70	37.91
✓ 6 Gauge x 1 1/2 inch (38mm), Box 100pcs	H8326	42.75	38.86
✓ 6 Gauge x 1 3/4 inch (44.5mm), Box 100pcs	H8327	54.30	49.36
✓ 6 Gauge x 2 inch (50mm), Box 100pcs	H8328	55.38	50.34
✓ 8 Gauge x 3/8 inch (10mm), Box 100pcs	H8330	27.33	24.84
✓ 8 Gauge x 1/2 inch (12mm), Box 100pcs	H8331	25.15	22.86
✓ 8 Gauge x 3/4 inch (19mm), Box 100pcs	H8332	28.30	25.73
✓ 8 Gauge x 1 inch (25mm), Box 100pcs	H8333	39.33	35.75
✓ 8 Gauge x 1 1/4 inch (32mm), Box 100pcs	H8334	41.70	37.91
✓ 8 Gauge x 1 1/2 inch (38mm), Box 100pcs	H8335	42.75	38.86
✓ 8 Gauge x 2 inch (50mm), Box 100pcs	H8336	54.30	49.36

H8300



SOLID BRASS ESCUTCHEON PINS

✓ 3.0 x 0.58 x 1.0mm Head Diam, 500pcs .023 x 1/8	H0670	12.63	11.48
✓ 6.35 x 1.00 x 1.6mm Head Diam, 100pcs	H0671	7.92	7.20
✓ 6.35 x 1.00 x 1.6mm Head Diam, 500pcs	H0672	31.68	28.80
✓ 6.35 x 1.80 x 3.40mm Head Diam, 100pcs	H0675	11.82	10.75
✓ 6.35 x 1.80 x 3.40mm Head Diam., 500pcs	H0676	47.28	42.98
✓ 9.5 x 1.00 x 2.25mm Head Diam, 100pcs	H0677	8.72	7.93
✓ 9.5 x 1.00 x 2.25mm Head Diam, 500pcs	H0678	34.88	31.71
✓ 9.5 x 1.25 x 2.25mm Head Diam, 100pcs	H0679	9.76	8.87
✓ 9.5 x 1.25 x 2.25mm Head Diam, 500pcs	H0680	38.14	34.67
✓ 9.5 x 1.65 x 3.3mm Head Diam, 100pcs	H0681	12.14	11.04
✓ 9.5 x 1.65 x 3.3mm Head Diam, 500pcs	H0682	46.47	42.25
✓ 9.5 x 2.1 x 4.0mm Head Diam, 100pcs	H0683	12.90	11.73
✓ 9.5 x 2.1 x 4.0mm Head Diam, 500pcs	H0684	51.60	46.91
✓ 12 x 1.0 x 2.2mm Head Diam, 100pcs	H0687	8.42	7.65
✓ 12 x 1.0 x 2.2mm Head Diam, 500pcs	H0688	33.68	30.62
✓ 12 x 1.6 x 3.3mm Head Diam., 100pcs	H0689	11.20	10.18
✓ 12 x 1.6 x 3.3mm Head Diam., 500pcs	H0690	33.58	30.52
✓ 12 x 1.0 x 1.6mm Head Diam, 100pcs	H0691	8.42	7.65
✓ 12 x 1.0 x 1.6mm Head Diam, 500pcs	H0692	33.68	30.62
✓ 12 x 1.25 x 2.25mm Head Diam, 100pcs	H0693	8.95	8.14
✓ 12 x 1.25 x 2.25mm Head Diam, 500pcs	H0694	35.80	32.55
✓ 12 x 1.15 x 3.3mm Head Diam, 100pcs	H0695	9.65	8.77
✓ 12 x 1.15 x 3.3mm Head Diam, 500pcs	H0696	38.60	35.09



✓ 12 x 1.25 x 2.25mm Head Diam, 100pcs	H0697	11.04	10.04
✓ 12 x 1.25 x 2.25mm Head Diam, 500pcs	H0698	44.16	40.15
✓ 16 x 1.25 x 2.25mm Head Diam, 100pcs	H0701	12.00	10.91
✓ 16 x 1.25 x 2.25mm Head Diam, 500pcs	H0702	48.00	43.64
✓ 16 x 1.6 x 3.3mm Head Diam., 100pcs	H0705	13.30	12.09
✓ 16 x 1.6 x 3.3mm Head Diam., 500pcs	H0706	39.85	36.23
✓ 16 x 2.0 x 4.3mm Head Diam., 100pcs	H0707	17.92	16.29
✓ 16 x 2.0 x 4.3mm Head Diam., 500pcs	H0708	67.08	60.98
✓ 19 x 1.00 x 2.25mm Head Diam, 100pcs	H0709	11.88	10.80
✓ 19 x 1.00 x 2.25mm Head Diam, 500pcs	H0710	47.52	43.20
✓ 19 x 1.25 x 2.25mm Head Diam, 100pcs	H0711	19.62	17.84
✓ 19 x 1.25 x 2.25mm Head Diam, 500pcs	H0712	78.48	71.35
✓ 19 x 1.65 x 3.3mm Head Diam,100pcs	H0713	23.28	21.16
✓ 19 x 1.65 x 3.3mm Head Diam, 500pcs	H0714	93.12	84.65
✓ 19 x 2.0 x 4.3mm Head Diam., 100pcs	H0715	16.45	14.95
✓ 19 x 2.0 x 4.3mm Head Diam., 500pcs	H0716	65.80	59.82
✓ 19 x 2.0 x 4.3mm Head Diam., 100pcs	H0717	17.15	15.59
✓ 19 x 2.0 x 4.3mm Head Diam., 500pcs	H0718	68.60	62.36
✓ 19 x 1.5 x 3.3mm Head Diam, 100pcs	H0719	23.28	21.16
✓ 19 x 1.5 x 3.3mm Head Diam, 500pcs	H0720	93.12	84.65
✓ 25 x 2.0 x 4.3mm Head Diam., 500pcs	H0728	112.00	101.82
✓ 32 x 1.6 x 3.3mm Head Diam., 100pcs	H0731	23.76	21.60
✓ 32 x 1.6 x 3.3mm Head Diam., 500pcs	H0732	79.26	72.06
✓ 32 x 2.0 x 3.3mm Head Diam., 100pcs	H0733	28.56	25.96
✓ 32 x 2.0 x 3.3mm Head Diam., 500pcs	H0734	95.00	86.36

STEEL PANEL PINS - ZINC PLATED

These pins were once the standard in quality and manufacture. British made and with a self countersinking head

✓ 15 x 1.00mm, 50gms (Approx. 465 pins)	H9404	18.74	17.04
✓ 15 x 1.00mm, 100gms (Approx. 935 pins)	H9405	32.98	29.98
✓ 15 x 1.00mm, 250gms (Approx. 2340 pins)	H9406	74.96	68.15
✓ 15 x 1.00mm, 500gms (Approx. 4680 pins)	H9407	134.93	122.66
✓ 20 x 1.00mm, 50gms (Approx. 355 pins)	H9409	17.81	16.19
✓ 20 x 1.00mm, 100gms (Approx. 710 pins)	H9410	31.35	28.50
✓ 20 x 1.00mm, 250gms (Approx. 1760 pins)	H9411	71.24	64.76
✓ 20 x 1.00mm, 500gms (Approx. 3530 pins)	H9412	128.23	116.57
✓ 25 x 1.25mm, 50gms (Approx. 210 pins)	H9434	16.28	14.80
✓ 25 x 1.25mm, 100gms (Approx. 405 pins)	H9435	28.65	26.05
✓ 25 x 1.25mm, 250gms (Approx. 1010 pins)	H9436	65.12	59.20
✓ 25 x 1.25mm, 500gms, (Approx. 2020 pins)	H9437	117.22	106.56
✓ 30 x 1.40mm, 50gms, (Approx. 130 pins)	H9449	15.86	14.42
✓ 30 x 1.40mm, 100gms, (Approx. 260 pins)	H9450	27.91	25.38
✓ 30 x 1.40mm, 250gms, (Approx. 650 pins)	H9451	63.44	57.67
✓ 30 x 1.40mm, 500gms, (Approx.1300 pins)	H9452	114.19	103.81



STAINLESS STEEL PANEL PINS

✓ 20 x 1.60mm, 50gms, (Approx. 148 pins)	H9459	29.45	26.77
✓ 20 x 1.60mm, 100gms, (Approx. 298 pins)	H9460	51.83	47.12
✓ 20 x 1.60mm, 250gms, (Approx. 745 pins)	H9461	117.80	107.09
✓ 20 x 1.60mm, 500gms, (Approx. 1490 pins)	H9462	212.04	192.76
✓ 25 x 1.60mm, 50gms, (Approx. 122 pins)	H9464	29.21	26.55
✓ 25 x 1.60mm, 100gms, (Approx. 245 pins)	H9465	51.41	46.74
✓ 25 x 1.60mm, 250gms, (Approx. 612 pins)	H9466	116.84	106.22
✓ 25 x 1.60mm, 500gms, (Approx. 1225 pins)	H9467	210.31	191.19
✓ 30 x 1.60mm, 50gms, (Approx. 105 pins)	H9469	34.52	31.38
✓ 30 x 1.60mm, 100gms, (Approx. 209 pins)	H9470	60.75	55.22
✓ 30 x 1.60mm, 250gms, (Approx. 522 pins)	H9471	138.06	125.51
✓ 30 x 1.60mm, 500gms, (Approx. 1045 pins)	H9472	248.51	225.92



SOLID BRASS PANEL PINS

- ✓ 15 x 1.40mm, 50gms, (Approx. 240 pins)
- ✓ 15 x 1.40mm, 100gms, (Approx. 486 pins)
- ✓ 15 x 1.40mm, 250gms, (Approx. 1215 pins)
- ✓ 15 x 1.40mm, 500gms, (Approx. 2430 pins)
- ✓ 20 x 1.40mm, 50gms, (Approx. 180 pins)
- ✓ 20 x 1.40mm, 100gms, (Approx. 360 pins)
- ✓ 20 x 1.40mm, 250gms, (Approx. 900 pins)
- ✓ 20 x 1.40mm, 500gms, (Approx. 1800 pins)
- ✓ 25 x 1.60mm, 50gms, (Approx. 113pins)
- ✓ 25 x 1.60mm, 100gms, (Approx. 226 pins)
- ✓ 25 x 1.60mm, 250gms, (Approx. 565 pins)
- ✓ 25 x 1.60mm, 500gms, (Approx. 1130 pins)
- ✓ 30 x 1.60mm, 50gms, (Approx. 95 pins)
- ✓ 30 x 1.60mm, 100gms, (Approx. 193 pins)
- ✓ 30 x 1.60mm, 250gms, (Approx. 482 pins)
- ✓ 30 x 1.60mm, 500gms, (Approx. 965 pins)
- ✓ 40 x 1.60mm, 50gms, (Approx, 50 pins)
- ✓ 40 x 1.60mm, 100gms, (Approx, 100pins)
- ✓ 40 x 1.60mm, 250gms, (Approx. 247 pins)
- ✓ 40 x 1.60mm, 500gms, (Approx. 495 pins)

H9483	32.24	29.31
H9484	56.74	51.58
H9485	128.96	117.24
H9486	232.13	211.03
H9493	31.76	28.87
H9494	55.90	50.82
H9495	127.04	115.49
H9496	228.67	207.88
H9498	31.40	28.55
H9499	55.26	50.24
H9500	125.60	114.18
H9501	226.08	205.53
H9503	31.40	28.55
H9504	55.26	50.24
H9505	125.60	114.18
H9506	226.08	205.53
H9508	31.40	28.55
H9509	55.26	50.24
H9510	125.60	114.18
H9511	226.08	205.53



SOLID BRASS COUNTERSUNK WASHERS

- ✓ for #6 Gauge Screws, 12 pc
- ✓ for #8 Gauge Screws, 12 pcs
- ✓ for #10 Gauge Screws, 12 pcs
- ✓ for #12 Gauge Screws, 12 pcs

H1050	9.33	8.48
H1051	12.67	11.52
H1052	14.06	12.78
H1053	15.13	13.75



BOX AND CABINET HARDWARE

PIVOT HINGES - OFFSET - BRASS

- ✓ 33.34mm x 7.94mm leaf, Pair, #L-23
- ✓ 44.45mm x 9.53mm leaf, Pair, #L-37
- ✓ Long Knuckle, 44.45mm x 9.53mm leaf, Pair, #L-39
- ✓ Brass, 50.80mm x 12.7mm leaf, Pair, #L-87

H7060	41.79	37.99
H7062	49.30	44.82
H7064	52.31	47.55
H7066	67.34	61.22



H7090

PIVOT HINGES - INLINE - BRASS

- ✓ 33.34mm x 7.94mm leaf, Pair, #ST-12
- ✓ 44.45mm x 9.53mm leaf, Pair, #ST-18
- ✓ 50.80mm x 12.7mm leaf, Pair, #ST-80

H7090	29.97	27.25
H7092	40.71	37.01
H7094	53.81	48.92



H7125

BUTT HINGES - BRASS

- ✓ Lift Off, 63.50mm x 44.45mm, LEFT HAND, Pair
- ✓ Lift Off, 63.50mm x 44.45mm, RIGHT HAND, Pair
- ✓ Triple Knuckle with Finial, 63.50mm x 44.45mm, Pair
- ✓ Full Mortise, 63.50mm x 46.04mm, Pair
- ✓ With Finial, Full Mortise, 63.50mm x 46.04mm, Pair
- ✓ Full Mortise, 63.50mm x 20.64mm, Pair
- ✓ With Finial, Full Mortise, 31.75mm x 20.64mm, Pair
- ✓ Full Mortise, 31.75mm x 26.99mm, Pair
- ✓ With Finial, Full Mortise, 31.75mm x 31.75mm, Pair
- ✓ Full Mortise, 50.8mm x 38.10mm, Pair
- ✓ Butt with Finial, Full Mortise, 50.8mm x 38.10mm, Pair

H7120	60.04	54.58
H7121	60.04	54.58
H7122	99.42	90.38
H7123	39.54	35.94
H7125	46.30	42.09
H7127	45.55	41.41
H7129	49.30	44.82
H7131	50.05	45.50
H7133	55.32	50.29
H7135	76.36	69.42
H7137	80.87	73.52



H7150



BOX FEET - BRASS

- ✓ 12.7mm diam., Proj. 9.53 mm, Pin diam 7.94 mm, 4 pcs
- ✓ 19.05mm diam., Proj. 14.29 mm, Pin diam. 12.70 mm, 4 pc
- ✓ 25.40mm diam., Proj. 3.18 mm, Pin diam. 15.88 mm
- ✓ 12.70mm diam., Proj. 23.81mm, Pin diam. 9.53 mm, 4 pcs
- ✓ 22.23 x 22.23mm, Thickness 6mm , 4 pcs

H7150	22.99	20.90
H7152	45.55	41.41
H7154	32.01	29.10
H7156	26.77	24.33
H7158	38.03	34.58

H7180



BOX HINGES - BRASS - 95 deg STAYED - PAIRS - WITH SCREWS

✓ Butt, 19.05mm long x 12.70mm wide, Pair, #JB-101	H7180	41.04	37.31
✓ Butt, 31.75mm long x 12.70mm wide, Pair, #JB-102	H7182	44.05	40.04
✓ Butt, 31.75mm long x 15.88mm wide, Pair, #JB-103	H7184	47.05	42.78
✓ Butt, 50.80mm long x 22.23mm wide, Pair, #JB-107	H7186	79.37	72.15
✓ Butt, 31.75mm long x 25.40mm wide, Pair, #JB-804	H7188	51.56	46.88
✓ Side Rail, 34.93mm x 7.94mm, Pair, #SR-638	H7192	52.88	48.07
✓ Side Rail, 50.80mm x 12.70mm, Pair, #SR-680	H7193	58.61	53.28

H7192 H7194

**SIDE RAIL - 180 DEGREE OPENING**

✓ Side Rail, 34.93mm x 7.94mm, #SR-301	H7194	55.75	50.68
--	-------	-------	-------

H7220 H7222

**BOX HOOKS - BRASS**

✓ 9.53mm diam., Proj. 23.81 mm, Pin diam.4.76mm, Ea.	H7220	13.22	12.02
✓ 41.28mm diam., Proj. 28.58 mm, Pin diam. 9.53mm, Ea.	H7222	61.47	55.88

H7240 H7260

**HANGING BRACKETS**

✓ Bracket, Hanging, Brass, 38.10mm x 15.88mm, Pair	H7240	22.99	20.90
--	-------	-------	-------

BOX KNOBS - SOLID BRASS

✓ 7.94mm diam., 7.94mm Proj., with 4.76mm pin, Each	H7260	10.21	9.29
✓ 11.11mm diam., 9.53mm Proj., with 4.76mm pin, Each	H7262	10.96	9.96
✓ 14.29mm diam., 12.70mm Proj., with 7.94mm pin, Each	H7264	12.48	11.34
✓ 17.46mm diam., 15.88mm Proj., with 9.53mm pin, Each	H7266	13.97	12.70

BOX LID STAYS - BRASS - PRICE FOR EACH

✓ 73.03 x 6.35mm Body,12.70mm deep, Anchor pin 6.35mm	H7280	38.02	34.56
✓ 109.54x9.53mm Body, 19.05mm deep, Anchor pin 11.11mm	H7281	63.59	57.81

H7280

**BOX QUADRANT HINGES - BRASS**

✓ Stayed at 95 degrees, each leaf 25.40mm x 25.40mm, Pair	H7290	70.35	63.95
✓ Stayed at 95 degrees, each leaf 38.10mm x 44.45mm, Pair	H7291	101.92	92.66

SHELF PINS & SOCKETS - BRASS

✓ Socket, 3/8 in. (9.53mm) dia.x 7/16 in.(11.11mm), per Doz.	H7310	37.28	33.89
✓ Pin, 1/4 inch (6.35mm) diam.x3/8 inch (9.53mm), per 4	H7312	24.50	22.28

H7290

**LATCHES & CATCHES - BRASS - EACH**

✓ Latch, Mortise, 34.93mm x 12.7mm x 9.53mm thick	H7350	53.81	48.92
✓ Latch, Mortise, 50.80mm x 19.05mm x 9.53mm thick	H7330	53.81	48.92
✓ Catch, Ball, with Keeper, 6.35mm diam.	H7332	17.80	16.18
✓ Catch, Ball, with Keeper, 8.73mm diam.	H7334	19.23	17.49
✓ Catch, Ball, with Keeper, 11.11mm diam.	H7336	22.24	20.22

BOX HARDWARE FITTING TEMPLATES

✓ Template, Each, #TJ-101	H7420	58.61	53.28
✓ Template, Each, #TJ-102	H7421	58.61	53.28
✓ Template, Each, #TJ-103	H7422	58.61	53.28
✓ for HD-638 Quadrant Hinge , Each, #TJ-638	H7423	58.61	53.28
✓ for HD-680 Quadrant Hinge , Each, #TJ-680	H7424	58.61	53.28
✓ for Series HD-702 Box Feet , Each, #TJ-702	H7425	58.61	53.28
✓ for Series JB-804 Series , Each, #TJ-804	H7426	58.61	53.28
✓ for Series JB-828 Series Latches, Each, #TJ-828	H7427	58.61	53.28

H7330 & H7350

**ESCUTCHEON PINS- SOLID BRASS NICKEL PLATED**

✓ 6.35 x 1.0 x 1.6mm Head Diam, 100pcs	H0650	8.16	7.42
✓ 6.35 x 1.0 x 1.6mm Head Diam, 500pcs	H0651	32.64	29.67
✓ 6.35 x 1.80 x 2.6mm Head Diam, 100pcs	H0652	15.68	14.25
✓ 6.35 x 1.80 x 2.6mm Head Diam, 500pcs	H0653	62.72	57.02
✓ 9.8 x 1.00 x 2.4mm Head Diam, 100pcs	H0654	20.10	18.27
✓ 9.8 x 1.00 x 2.4mm Head Diam, 500pcs	H0655	80.40	73.09
✓ 9.8 x 1.25 x 2.2mm Head Diam, 100pcs	H0656	20.10	18.27
✓ 9.8 x 1.25 x 2.2mm Head Diam, 500pcs	H0657	80.40	73.09
✓ 12.5 x 1.25 x 2.2mm Head Diam, 100 pcs	H0658	22.56	20.51
✓ 12.5 x 1.25 x 2.2mm Head Diam, 500 pcs	H0659	90.24	82.04



RARE EARTH MAGNETS

- ✓ Disc, Neodymium, 6mm diam x 2mm thick, pkt 4
- ✓ Disc, Neodymium, 6mm diam x 2mm thick, pkt 12
- ✓ Disc, Neodymium, 8mm diam x 5.0mm thick, 4 pcs
- ✓ Disc, Neodymium, 10mm diam x 1.5mm thick, 4 pcs
- ✓ Disc, Neodymium, 10mm diam x 3.0mm thick, 4 pcs
- ✓ Disc, Neodymium, 12mm diam x 5.0mm thick, 4 pcs
- ✓ Disc, Neodymium, 12mm diam x 6.6mm thick, 4 pcs

ITEM	RRP	Ex GST
H6000	6.05	5.50
H6001	18.15	16.50
H6002	9.68	8.80
H6003	7.26	6.60
H6004	11.00	10.00
H6005	23.65	21.50
H6006	31.46	28.60



MEDIA STORAGE

These storage racks for DVD, CD cases are an ideal basis for a school project. Spring finger racks hold in place by the pressure from spring loaded plastic fingers which partly eject the case when it is pressed and disengaged from the rack. These racks are suited to tower use or used flat on their backs in a drawer arrangement.

SPRING FINGER STYLE RACK - LH & RH SET

- ✓ CD Insert, holds 20, 1 set, #4196
- ✓ CD Insert, holds 20, 100 Sets, #4196
- ✓ DVD Insert, holds 15, 1 set, #4161
- ✓ DVD Insert, holds 15, 100 sets, #4161

ITEM	RRP	Ex GST
P0120	9.50	8.64
P0125	787.50	715.91
P0150	4.58	4.16
P0155	420.00	381.82

Spring Finger Styles



GRILLE STYLE

- ✓ Rack, CD, Grille Style, holds 9, each, #FWCD-9V
- ✓ Rack, CD, Grille Style, holds 9, 200 pcs, #FWCD-9V
- ✓ Rack, DVD, Grille Style, holds 7, each, #FWDVD-7V
- ✓ Rack, DVD, Grille Style, holds 7, 200 pcs, #FWDVD-7V

P0160	4.58	4.16
P0161	420.00	381.82
P0170	4.87	4.43
P0171	580.00	527.27

Drawer Styles



DRAWER STYLE - LH & RH SET

- ✓ Tray, CD Storage, for Drawer, holds 26 CD's, 1 set
- ✓ Tray, CD Storage, for Drawer, holds 26 CD's, 100 sets
- ✓ Tray, DVD Storage, for Drawer, holds 13 DVD's, 1 set
- ✓ Tray, DVD Storage, for Drawer, holds 13 DVD's, 100 sets

P0180	6.83	6.21
P0181	537.50	488.64
P0195	6.83	6.21
P0196	537.50	488.64

BALL-POINT PEN MAKING ON THE LATHE

These ball point pen mechanisms allow turned pens to be made on the lathe. A mandrell to hold the pen sections is strongly advised and a pen mill to square the ends on the sections prior to turning helps produce a high quality result. The brass tubes require a brad point 7mm drill

- ✓ Pen Sets, Ball Point Twist, Gold Clip, pkt 5
- ✓ Pen Sets, Ball Point Twist, Plain Black Clip, pkt 5
- ✓ Pen Sets, Ball Point Twist, Australia Black Clip, pkt 5
- ✓ Tube, 7mm Brass, Spare, 6 pcs
- ✓ Mandrell, Pen, for dual 7mm Core tubes, #2 Morse Taper
- ✓ Mill, Pen, for 7mm bore tube
- ✓ Drill, Brad Point, 7mm, Stubai

ITEM	RRP	Ex GST
P0003	24.95	22.68
P0001	24.95	22.68
P0005	24.95	22.68
P0029	3.20	2.91
A0295	39.00	35.45
A0299	54.00	49.09
T3534	3.77	3.43

A0299



P0003 - P0005



A0295



T3534



SALT & PEPPER MILL GRINDERS ON THE LATHE

Salt and pepper mills are a popular project for wood turners. The ready availability of mechanisms - metal for pepper and hard plastic for salt - requires only the mill body and top to be made. Any wood can be used with the possible exception of highly scented or resinous woods which may tend to taint the contents.

	ITEM	RRP	Ex GST
✓ Mill, Salt, Kit, Silver Knob, 5 inch, #S1005	P0720	15.18	13.80
✓ Mill, Salt, Kit, Silver Knob, 7 inch, #S1010	P0721	15.32	13.93
✓ Mill, Salt, Kit, Silver Knob, 8 inch, #S1015	P0722	15.57	14.16
✓ Mill, Salt, Kit, Silver Knob, 10 inch, #S1020	P0723	15.94	14.49
✓ Mill, Salt, Kit, Silver Knob, 12 inch, #S1030	P0724	16.45	14.95
✓ Mill, Salt, Kit, Silver Knob, 15 inch, #S1040	P0725	17.20	15.64
✓ Mill, Salt, Kit, Silver Knob, 17 inch, #S1050	P0726	17.71	16.10
<hr/>			
✓ Mill, Salt, Kit, Brass Knob, 5 inch, #S1005B	P0728	14.42	13.11
✓ Mill, Salt, Kit, Brass Knob, 7 inch, #S1010B	P0729	15.32	13.93
✓ Mill, Salt, Kit, Brass Knob, 8 inch, #S1015B	P0730	14.81	13.47
✓ Mill, Salt, Kit, Brass Knob, 10 inch, #S1020B	P0731	15.18	13.80
✓ Mill, Salt, Kit, Brass Knob, 12 inch, #S1030B	P0732	15.69	14.26
✓ Mill, Salt, Kit, Brass Knob, 15 inch, #S1040B	P0733	16.19	14.72
✓ Mill, Salt, Kit, Brass Knob, 17 inch, #S1050B	P0734	16.45	14.95
<hr/>			
✓ Mill, Pepper, Kit, Black Knob, 5 inch, #S2005	P0736	15.18	13.80
✓ Mill, Pepper, Kit, Black Knob, 7 inch, #S2010	P0737	15.32	13.93
✓ Mill, Pepper, Kit, Black Knob, 8 inch, #S2015	P0738	15.57	14.16
✓ Mill, Pepper, Kit, Black Knob, 10 inch, #S2020	P0739	15.94	14.49
✓ Mill, Pepper, Kit, Black Knob, 12 inch, #S2030	P0740	16.45	14.95
✓ Mill, Pepper, Kit, Black Knob, 15 inch, #S2040	P0741	17.20	15.64
✓ Mill, Pepper, Kit, Black Knob, 17 inch, #S2050	P0742	17.71	16.10
<hr/>			
✓ Mill, Pepper, Kit, Brass Knob, 5 inch, #S2005B	P0744	14.42	13.11
✓ Mill, Pepper, Kit, Brass Knob, 7 inch, #S2010B	P0745	15.32	13.93
✓ Mill, Pepper, Kit, Brass Knob, 8 inch, #S2015B	P0746	14.81	13.47
✓ Mill, Pepper, Kit, Brass Knob, 10 inch, #S2020B	P0747	15.18	13.80
✓ Mill, Pepper, Kit, Brass Knob, 12 inch, #S2030B	P0748	15.69	14.26
✓ Mill, Pepper, Kit, Brass Knob, 15 inch, #S2040B	P0749	16.19	14.72
✓ Mill, Pepper, Kit, Brass Knob, 17 inch, #S2050B	P0750	16.45	14.95

Pepper Kits



Salt Kits



T3533



PEPPER & SALT MILL MAKING EQUIPMENT

	ITEM	RRP	Ex GST
✓ Borer, Universal, 35mm, Stubai	T0339	40.28	36.62
✓ Drill, Brad Point, 6mm, Stubai	T3533	3.65	3.32

TOY WHEEL CUTTERS

✓ Cutter, Toy Wheel, 40mm TWC40 1/2	T0200	108.65	98.77
✓ Cutter, Toy Wheel, 50mm TWC 50 1/2	T0202	115.50	105.00
✓ Cutter, Toy Wheel, 60mm TWC 60 1/2	T0201	115.50	105.00



INSERT & CONCEALED MECHANISM QUARTZ CLOCKS

Concealed mechanism clocks can be recessed into the rear side of a piece of wood and hands fitted to the shank which protrudes through the body. There are numerous hand patterns to suit concealed mechanism clocks and numerals in Arabic & Roman styles. Purchase price of items P4007, P4008 & P4009 includes a set of hands and numerals of choice.

Insert clocks can be pressed into a machined or drilled front recess. Batteries are not supplied.

CONCEALED QUARTZ MECHANISMS

	ITEM	RRP	Ex GST
✓ Clock, with numerals & hands, 8mm short shaft	P4007	15.35	13.95
✓ Clock, with numerals & hands, 15mm medium shaft	P4008	15.35	13.95
✓ Clock, with numerals & hands, 21mm long shaft	P4009	15.35	13.95



CLOCK FACE NUMERALS

- ✓ ARABIC GOLD, 10mm (3/8inch)
- ✓ ARABIC GOLD, 16mm (5/8inch)
- ✓ ARABIC GOLD, 19mm (3/4inch)
- ✓ ARABIC GOLD, 25mm (1inch)
- ✓ ARABIC BLACK, 10mm (3/8 inch)
- ✓ ARABIC BLACK, 16mm (5/8inch)
- ✓ ARABIC BLACK, 19mm (3/4 inch)
- ✓ ARABIC BLACK, 25mm (1 inch)
- ✓ ROMAN GOLD, 10mm (3/8 inch)
- ✓ ROMAN GOLD, 16mm (5/8inch)
- ✓ ROMAN GOLD, 19mm (3/4inch)
- ✓ ROMAN GOLD, 25mm (1 inch)

ITEM	RRP	Ex GST
P4150	4.71	4.28
P4151	4.89	4.44
P4152	5.42	4.93
P4153	5.77	5.25
P0241	4.71	4.28
P4155	4.89	4.44
P0247	5.42	4.93
P0249	5.77	5.25
P0231	4.71	4.28
P4157	4.89	4.44
P4158	5.42	4.93
P0239	5.77	5.25



CLOCK HANDS FOR CONCEALED QUARTZ MOVEMENTS

For pictures of alternative clock hand patterns search using the Item Code at www.thewoodworks.com.au

for 50mm to 80mm DIALS

- ✓ for 50mm to 80mm DIALS, 35mm, GOLD, Type B
- ✓ for 50mm to 80mm DIALS, 35mm, Black, Type B
- ✓ for 50mm to 80mm DIALS, 35mm, Gold, Type C
- ✓ for 50mm to 80mm DIALS, 35mm, Black, Type C
- ✓ for 50mm to 80mm DIALS, 38mm, Gold, Type D
- ✓ for 50mm to 80mm DIALS, 38mm, Gold, Type E
- ✓ for 50mm to 80mm DIALS, 38mm, Black, Type E

ITEM	RRP	Ex GST
P4041	2.90	2.64
P4042	2.90	2.64
P4043	2.90	2.64
P4044	2.90	2.64
P4045	2.90	2.64
P4046	2.90	2.64
P4047	2.90	2.64

for 90mm to 125mm DIALS

- ✓ for 90mm to 125mm DIALS, 44mm, Gold, Type A
- ✓ for 90mm to 125mm DIALS, 48mm, Black, Type B
- ✓ for 90mm to 125mm DIALS, 52mm, Gold, Type C
- ✓ for 90mm to 125mm DIALS, 52mm, Gold, Type D
- ✓ for 90mm to 125mm DIALS, 54mm, Black, Type E
- ✓ for 90mm to 125mm DIALS, 57mm, Gold, Type F
- ✓ for 90mm to 125mm DIALS, 57mm, Black, Type F
- ✓ for 90mm to 125mm DIALS, 64mm, Gold, Type G
- ✓ for 90mm to 125mm DIALS, 64mm, Black, Type G

P4060	2.95	2.68
P4062	2.95	2.68
P4063	2.95	2.68
P4065	2.95	2.68
P4066	2.95	2.68
P4067	2.95	2.68
P4068	2.95	2.68
P4069	2.95	2.68
P4070	2.95	2.68

for 150mm to 210mm DIALS

- ✓ for 150mm to 210mm DIALS, 76mm, Gold, Type A
- ✓ for 150mm to 210mm DIALS, 76mm, Black, Type A
- ✓ for 150mm to 210mm DIALS, 79mm, Gold, Type B
- ✓ for 150mm to 210mm DIALS, 79mm, Black, Type B
- ✓ for 150mm to 210mm DIALS, 86mm, Black, Type C
- ✓ for 150mm to 210mm DIALS, 89mm, Gold, Type D
- ✓ for 150mm to 210mm DIALS, 89mm, Black, Type D
- ✓ for 150mm to 210mm DIALS, 103mm, Black, Type E
- ✓ for 150mm to 210mm DIALS, 105mm, Gold, Type F
- ✓ for 150mm to 210mm DIALS, 105mm, Black, Type F

P4080	3.35	3.05
P4081	3.35	3.05
P4082	3.35	3.05
P4083	3.35	3.05
P4084	3.35	3.05
P4085	3.35	3.05
P4086	3.35	3.05
P4087	3.35	3.05
P4088	3.35	3.05
P4089	3.35	3.05

Example hand set



SECOND HANDS

- ✓ for Quartz Clock Movement, 61mm, Gold, Type G
- ✓ for Quartz Clock Movement, 61mm, Black, Type G
- ✓ for Quartz Clock Movement, 61mm, Red, Type G

P4110	2.70	2.45
P4111	2.70	2.45
P4112	2.70	2.45

P3020

INSERT CLOCK MECHANISMS / MOVEMENTS

- ✓ 36mm diameter, GOLD ARABIC
- ✓ 36mm diameter, GOLD ROMAN
- ✓ 36mm diameter, WHITE ARABIC
- ✓ 36mm diameter, WHITE ROMAN
- ✓ 36mm diameter, BLACK ARABIC
- ✓ 36mm diameter, BLACK ROMAN
- ✓ 36mm diameter, CREAM ARABIC
- ✓ 36mm diameter, CREAM ROMAN
- ✓ 50mm diameter, GOLD ROMAN
- ✓ 50mm diameter, WHITE ROMAN
- ✓ 50mm diameter, GOLD ARABIC
- ✓ 50mm diameter, WHITE ARABIC
- ✓ 50mm diameter, BLACK ROMAN

P3000	23.98	21.80
P3001	23.98	21.80
P3002	23.98	21.80
P3003	23.98	21.80
P3004	23.98	21.80
P3005	23.98	21.80
P3006	23.98	21.80
P3007	23.98	21.80
P3020	27.94	25.40
P3021	27.94	25.40
P3022	27.94	25.40
P3023	27.94	25.40
P3024	27.94	25.40



- ✓ 73mm diameter, GOLD ARABIC
- ✓ 73mm diameter, GOLD ROMAN
- ✓ 73mm diameter, WHITE FANCY ARABIC
- ✓ 73mm diameter, WHITE FANCY ROMAN
- ✓ 73mm diameter, IVORY FANCY ARABIC
- ✓ 73mm diameter, IVORY FANCY ROMAN
- ✓ 90mm diameter, GOLD ARABIC
- ✓ 90mm diameter, GOLD ROMAN
- ✓ 90mm diameter, WHITE FANCY ARABIC
- ✓ 90mm diameter, WHITE FANCY ROMAN
- ✓ 90mm diameter, IVORY FANCY ARABIC
- ✓ 90mm diameter, IVORY FANCY ROMAN
- ✓ 90mm diameter, BLACK ROMAN
- ✓ 130mm diameter, IVORY FANCY ARABIC
- ✓ 130mm diameter, GOLD ROMAN
- ✓ 130mm diameter, GOLD ARABIC
- ✓ 160mm diameter, GOLD ROMAN
- ✓ 160mm diameter, IVORY FANCY ARABIC
- ✓ 160mm diameter, GOLD ARABIC

P3040	28.60	26.00
P3041	28.60	26.00
P3042	28.60	26.00
P3043	28.60	26.00
P3044	28.60	26.00
P3045	28.60	26.00
P3060	28.60	26.00
P3061	28.60	26.00
P3062	28.60	26.00
P3063	28.60	26.00
P3064	28.60	26.00
P3065	28.60	26.00
P3066	28.60	26.00
P3080	52.14	47.40
P3081	52.14	47.40
P3082	52.14	47.40
P3090	59.07	53.70
P3091	59.07	53.70
P3092	59.07	53.70

CONSUMABLES

ADHESIVES

All our PVA range is made in Australia from quality fresh ingredients.

Our renowned "yellow" PVA has superior strength, good sandability and quick cure.

The crosslinking PVA has the strongest bond of them all.

The White Sandable is an ultra hard cure PVA which cures slowly & allows time for complex glue ups.

	ITEM	RRP	Ex GST
✓ White Crosslinking PVA, T3275, 500ml, (decant)	C0097	12.37	11.24
✓ White Crosslinking PVA, T3275, 1 Litre, (decant)	C0098	15.20	13.82
✓ White Crosslinking PVA, T3275, 5 litres, (decant)	C0099	54.00	49.09
✓ White Crosslinking PVA, T3275, 20 litres	C0100	190.40	173.09
✓ White Sandable PVA, Slow Cure, T3223, 500ml, (decant)	C0103	11.84	10.77
✓ White Sandable PVA, Slow Cure, T3223, 1 Litre, (decant)	C0104	14.40	13.09
✓ White Sandable PVA, Slow Cure, T3223, 5 Litres (decant)	C0105	50.40	45.82
✓ White Sandable PVA, Slow Cure, T3223, 20 Litres	C0106	176.80	160.73
✓ Water Resistant, Yellow PVA, T3250, 500ml, (decant)	C0109	11.46	10.42
✓ Water Resistant, Yellow PVA, T3250, 1 Litre, (decant)	C0110	13.82	12.56
✓ Water Resistant, Yellow PVA, T3250, 5 Litres (decant)	C0111	47.79	43.45
✓ Water Resistant, Yellow PVA, T3250, 20 Litres	C0112	166.94	151.76

ANIMAL PROTEIN GLUE

✓ Adhesive, Hide, Pearl Joiners, 1kg	C0081	23.25	21.14
✓ Adhesive, Hide, Pearl Joiners, 2kg	C0082	47.15	42.86
✓ Adhesive, Hide, Pearl Joiners, 5kg	C0083	116.55	105.95

BISCUITS

	ITEM	RRP	Ex GST
✓ Biscuits, #0, pkt 100	C0400	9.90	9.00
✓ Biscuits, #10, pkt 100	C0401	9.90	9.00
✓ Biscuits, #20, pkt 100	C0402	9.90	9.00
✓ Biscuits, #0, box 1000	C0410	62.70	57.00
✓ Biscuits, #10, box 1000	C0411	65.00	59.09
✓ Biscuits, #20, box 1000	C0412	65.00	59.09

FLUTED DOWEL - TASMANIAN OAK - CUT TO LENGTH

✓ 6mm x 38mm, 72 grams (approx. 100 pcs)	C0414	5.76	5.24
✓ 6mm x 38mm, 720 gms (approx 1000 pcs)	C0415	57.59	52.36
✓ 8mm x 50mm, 158 grams (approx 100 pcs)	C0418	7.46	6.78
✓ 8mm x 50mm, 1580 grams (approx. 1000 pcs)	C0419	74.56	67.78
✓ 10mm x 50mm, 282 grams (approx. 100 pcs)	C0422	10.63	9.67
✓ 10mm x 50mm, 2820 gms (approx. 1000 pcs)	C0423	106.33	96.67
✓ 10mm x 62mm, 349 grams (approx 100 pcs)	C0424	13.19	11.99
✓ 10mm x 62mm, 3490 grams (approx 1000 pcs)	C0425	131.86	119.88

PVA Glues



Biscuits



Dowels



FESTO DOMINO SLIP TENONS

- ✓ 5 x 30mm, 1800 pcs (6 pks x 300), #493 296
- ✓ 6 x 40mm, 1140 pcs (6 pks x 190), #493 297
- ✓ 8 x 40mm, 780 pcs (6 pks x 130), #493 298
- ✓ 8 x 50mm, 600 pcs (6 pks x 100), #493 299
- ✓ 10 x 50mm, 510 pcs (6 pks x 85), #493 300

C0394	184.00	167.27
C0395	184.00	167.27
C0396	184.00	167.27
C0397	184.00	167.27
C0398	184.00	167.27

Dominos



PICTURE FRAMING V NAILS

- ✓ V Nails, 7mm Hardwood, framing, pkt 400
- ✓ V Nails, 10mm Hardwood, framing, pkt 400
- ✓ V Nails, 15mm Hardwood, framing, pkt 400

C0821	9.95	9.05
C0822	10.95	9.95
C0824	12.95	11.77

Putty Bricks



PUTTY BRICKS - AUSTRALIAN MADE

Ideal for repair of dings & gaps. Boxes of 20 mixed colours, bags of 5 of any one colour & bags of 10 wood tones.

- ✓ 75 x 15 x 15mm, 10 WOOD TONE colours
- ✓ 75 x 15 x 15mm, 20 colours, #APB 1
- ✓ 5 pcs, 75 x 15 x 15mm, Pine, #WPB 20
- ✓ 5 pcs, 75 x 15 x 15mm, Baltic, #WPB 43

C3945	29.98	27.25
C3946	49.95	45.41
C3958	14.95	13.59
C3981	14.95	13.59

SHELLAC

Cured shellac is safe enough to be rated as a food and offers a quick and safe method of achieving a quality finish on numerous projects. The best method of ensuring a long shelf life and superior finishes is to use DAA (Denatured Absolute Alcohol) Spirits.

It is important that the DAA can be appropriately stored. A standard concentrate is simply and quickly made up using a 1 to 4 ratio of dry shellac by weight to DAA spirits by liquid volume. e.g. 500gms mixed with 2 litres of DAA.

DAA SPIRITS

- ✓ Spirits, DAA, 100% Industrial Alcohol, 1 litre
- ✓ Spirits, DAA, 100% Industrial Alcohol, 5 litres
- ✓ Spirits, DAA, 100% Industrial Alcohol, 20 litres

ITEM	RRP	Ex GST
C2266	16.95	15.41
C2267	42.95	39.05
C2270	115.58	105.07

Orange



DRY SHELLACS

- ✓ Shellac, Orange Flake, Waxy, 125gms
- ✓ Shellac, Orange Flake, Waxy, 250gms
- ✓ Shellac, Orange Flake, Waxy, 500gms
- Shellac, Orange Flake, Waxy, 1 kilo
- Shellac, Orange Flake, Waxy, 5 kilo
- ✓ Shellac, Button, Waxy, 125gms
- ✓ Shellac, Button, Waxy, 250gms
- ✓ Shellac, Button, Waxy, 500gms
- ✓ Shellac, Button, Waxy, 1 kilo
- ✓ Shellac, Button, Waxy, 5 kilo
- ✓ Shellac, Garnet Flake, De-Waxed, 125gms
- ✓ Shellac, Garnet Flake, De-Waxed, 250gms
- ✓ Shellac, Garnet Flake, De-Waxed, 500gms
- ✓ Shellac, Garnet Flake, De-Waxed, 1 kilo
- ✓ Shellac, Garnet Flake, De-Waxed, 5 kilo
- ✓ Shellac, Ruby Flake, De-Waxed 125gms
- ✓ Shellac, Ruby Flake, De-Waxed 250gms
- ✓ Shellac, Ruby Flake, De-Waxed 500gms
- ✓ Shellac, Ruby Flake, De-Waxed 1 kilo
- ✓ Shellac, Ruby Flake, De-Waxed 5 kilo
- ✓ Shellac, Blonde, De-Waxed, Flake, 125gms
- ✓ Shellac, Blonde, De-Waxed, Flake, 250gms
- ✓ Shellac, Blonde, De-Waxed, Flake, 500gms
- ✓ Shellac, Blonde, De-Waxed, Flake, 1 kilo
- ✓ Shellac, Blonde, De-Waxed, Flake, 5 kilo
- ✓ Shellac, White, Waxy, Granulated, 125gms
- ✓ Shellac, White, Waxy, Granulated, 250gms
- ✓ Shellac, White, Waxy, Granulated, 500gms
- ✓ Shellac, White, Waxy, Granulated, 1 kilo
- ✓ Shellac, White, Waxy, Granulated, 5 kilo

C2410	9.24	8.40
C2411	16.17	14.70
C2412	30.03	27.30
C2413	57.29	52.08
C2414	254.10	231.00
C2420	10.65	9.68
C2421	18.64	16.94
C2422	34.61	31.47
C2423	66.03	60.03
C2424	292.88	266.25
C2430	10.73	9.75
C2431	18.77	17.06
C2432	34.86	31.69
C2433	66.50	60.45
C2434	294.94	268.13
C2440	11.32	10.29
C2441	19.81	18.01
C2442	36.79	33.45
C2443	70.18	63.80
C2444	311.30	283.00
C2460	14.97	13.60
C2461	26.19	23.81
C2462	48.64	44.21
C2463	92.78	84.35
C2464	411.54	374.13
C2490	25.59	23.26
C2491	44.78	40.71
C2492	83.17	75.61
C2493	158.66	144.23
C2494	703.73	639.75

Button



Garnet



Ruby



Blonde



Waxy White



✓ Shellac, White, De-Waxed, Granulated, 125gms	C2500	15.57	14.15
✓ Shellac, White, De-Waxed, Granulated, 250gms	C2501	27.25	24.77
✓ Shellac, White, De-Waxed, Granulated, 500gms	C2502	50.60	46.00
✓ Shellac, White, De-Waxed, Granulated, 1 kilo	C2503	96.53	87.76
✓ Shellac, White, De-Waxed, Granulated, 5 kilo	C2504	428.18	389.25

De-Waxed White



READY MIX - supplied in Dangerous Goods Packaging REGULAR FRENCH POLISH

✓ Orange, Ready Mixed, 1 litre DG Packed	C2510	35.34	32.13
✓ Orange, Ready Mixed, 5 litre DG Packed	C2511	102.72	93.38
✓ Waxy White, Ready Mixed, 1 litre DG Packed	C2513	57.71	52.46
✓ Waxy White, Ready Mixed, 5 litre DG Packed	C2514	173.01	157.28
✓ De Waxed White, Ready Mixed, 1 litre DG Packed	C2516	49.83	45.30
✓ De Waxed White, Ready Mixed, 5 litre DG Packed	C2517	148.26	134.78
✓ Blonde, Dewaxed, Ready Mixed, 1 litre DG Packed	C2522	64.01	58.19
✓ Blonde, Dewaxed, Ready Mixed, 5 litre DG Packed	C2523	192.81	175.28

C2510



HARD FRENCH POLISH

✓ Orange, Ready Mixed, HARD, 1 litre DG Packed	C2526	123.54	112.31
✓ Orange, Ready Mixed, HARD, 5 litre DG Packed	C2527	379.92	345.38
✓ Waxy White, Ready Mixed, HARD, 1 litre DG Packed	C2529	145.91	132.64
✓ Waxy White, Ready Mixed, HARD, 5 litre DG Packed	C2530	450.21	409.28
✓ De Waxed White, Ready Mixed, HARD, 1 litre DG Packed	C2532	138.03	125.48
✓ De Waxed White, Ready Mixed, HARD, 5 litre DG Packed	C2533	425.46	386.78
✓ Blonde, Dewaxed, Ready Mixed, HARD, 1 litre DG Packed	C2538	88.11	80.10
✓ Blonde, Dewaxed, Ready Mixed, HARD, 5 litre DG Packed	C2539	359.91	327.19

Pure Tung Oil



FINISHING OILS & WAXES

Our tung oil is pure whereas most formulations marketed as tung oil contain only a small amount of tung oil
Tung oil is non toxic, applicable for use as a finish on kitchen utensils and children's toys.

✓ Oil, Tung, Pure, 1 Litre	C2891	45.94	41.76
✓ Oil, Tung, Pure, 5 Litre	C2893	172.44	156.76
✓ Wax, Bees, Mirowax 738, 230gms (re-packed)	C7035	19.45	17.68
✓ Wax, Bees, 3 kilos	C7037	194.55	176.86

Beeswax



HOOK & LOOP STARTER PADS

✓ 200mm, Pressure Sensitive Adhesive Backing	A4138	5.22	4.75
✓ 230mm, Pressure Sensitive Adhesive Backing	A4139	15.68	14.25
✓ 250mm, Pressure Sensitive Adhesive Backing	A4140	5.22	4.75
✓ 280mm, Pressure Sensitive Adhesive Backing	A4141	5.22	4.75
✓ 300mm, Pressure Sensitive Adhesive Backing	A4142	29.70	27.00
✓ 350mm, Pressure Sensitive Adhesive Backing	A4143	5.22	4.75

ABRASIVE DISCS - HOOK & LOOP BACKED - PACKETS OF 10

✓ 230mm, 40grit	D3277	48.00	43.64
✓ 230mm, 60grit	D3278	40.20	36.55
✓ 230mm, 80grit	D3279	38.40	34.91
✓ 230mm, 120grit	D3280	37.40	34.00
✓ 250mm, 40grit	D3281	53.40	48.55
✓ 250mm, 60grit	D3282	47.40	43.09
✓ 250mm, 80grit	D3283	46.40	42.18
✓ 250mm, 120grit	D3284	45.00	40.91
✓ 300mm, 40grit	D3285	67.60	61.45
✓ 300mm, 60grit	D3286	65.80	59.82
✓ 300mm, 80grit	D3287	63.00	57.27
✓ 300mm, 120grit	D3288	62.40	56.73
✓ 350mm, 40grit	D3289	96.60	87.82
✓ 350mm, 60grit	D3290	93.40	84.91
✓ 350mm, 80grit	D3291	91.20	82.91
✓ 350mm, 120grit	D3292	88.20	80.18



ABRASIVE DISCS - CLOTH BACKED - PACKETS OF 10

✓ 10 discs, 300mm, 40grit	D3305	148.60	135.09
✓ 10 discs, 300mm, 60grit	D3306	135.00	122.73
✓ 10 discs, 300mm, 80grit	D3307	126.40	114.91
✓ 10 discs, 300mm, 120grit	D3308	118.80	108.00
✓ 10 discs, 350mm, 40grit	D3309	204.80	186.18
✓ 10 discs, 350mm, 60grit	D3310	185.60	168.73
✓ 10 discs, 350mm, 80grit	D3311	169.80	154.36
✓ 10 discs, 350mm, 120grit	D3312	160.80	146.18

C0390



DISC CEMENT

✓ Cement, Disc, for Disc Sander cloth back pads, 500ml	C0390	42.15	38.32
✓ Restorer, Abrasive Disc /Belt	A4135	5.22	4.75

A4135



BOBBIN SANDER SLEEVES & SANDING BELTS

We can supply for any machine in a range of grits. Minimum orders apply - please email or call.

WOOD CARVING

Wood Works carries the largest and most comprehensive range of woodcarving tools in Australia. The hand forged #52 series tool from Stubai in the Austrian Tyrol are an excellent starter kit. The hand forged #55 series are a slightly longer pattern with polished flute.

	ITEM	RRP	Ex GST
✓ Chisel, Carving, Set, Boxed, Stubai, 52 Series, 6 piece	F4925	130.89	118.99
✓ Chisel, Carving, Set, Stubai, 55 Series, 6 Piece	F4932	258.11	234.64
✓ Chisel, Carving, Set, Stubai, Micro Series, 6 Piece	F4942	147.91	134.46
✓ Mallet, Carver's, 70mm Diam, 400gram, #511001	T3365	29.25	26.59
✓ Screw, Carver's, 150mm x 10mm, #3506	E2180	56.75	51.59

T3365



F4981



F4990



F4942



E2180

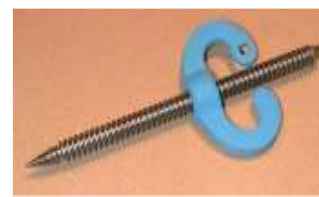

HAND TOOLS

We supply in excess of 8,000 items from manufacturers across the world. The hand tool listing below is only a small part of the range we offer and is filtered by our long experience in dealing with schools. Please contact us for items not listed below. We refuse to market what amounts to landfill and, as a response to the extremely poor quality tools and equipment being offered to many schools and the concerns expressed to us more or less daily by teachers having to use these items, we also note the country of origin and recognised brands of the tools we sell. All our tools come with warranty and all have brands which are meaningful and manufactured by reputable makers.

WARRINGTON (CROSS PEIN) TACK HAMMERS & DUAL PINION EGGBEATER DRILL - GERMAN MADE

✓ 125g, (4.5 oz), #2008 / 125	T4369	39.23	35.66
✓ 180g, (6oz), #2008 / 180	T4370	43.10	39.18
✓ Drill, Hand, Double Pinion, 10mm, #2551	T0495	67.41	61.28



CABINET SCRAPERS- GERMAN AND AUSTRIAN MADE-KIRSCHEN AND STUBAI

- ✓ 1.2mm, 140mm x 50mm, Rectangular Heavy Gauge
- ✓ 1.2mm, 160mm x 60mm, Rectangular Heavy Gauge
- ✓ 0.6mm, 150mm x 50mm, Rectangular
- ✓ 0.8mm, 150mm x 50mm, Rectangular
- ✓ 0.8mm Goose Neck
- ✓ 0.8mm, 150mm x 50mm, Concave/Convex
- ✓ Burnisher, Round, 120mm

	T1698	5.45	4.95
	T1699	5.95	5.41
	T1700	7.15	6.50
	T1701	7.15	6.50
	T1702	8.10	7.36
	T1703	6.48	5.89
	T1711	16.95	15.41

T1698 - T1701

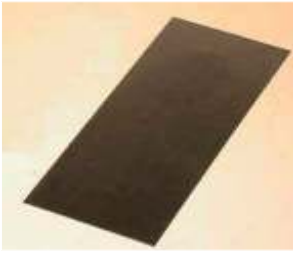

T1702



T1703



T1711



COPING SAWS - GERMAN MADE - BOKER

- ✓ Saw, Coping, Boker, #160
- ✓ Blades, Coping, Pinned, pkt 12, #470

ITEM	RRP	Ex GST
T1581	26.95	24.50
L1903	8.29	7.53

JAPANESE HAND SAWS - GYOKUCHO

Japanese pull-action saws have a far superior cutting action which is within the ability of the absolute beginner wood worker. They are ideal for use in schools at all ages and replaceable blades take years to lose their edge. A Dozuki is equivalent to a western dovetail or tenon saw.

- ✓ Dozuki Noko, 0.3 x 180mm, EVA Handle, #297
- ✓ Dozuki Noko, 0.3 x 180mm, EVA Handle, #297, Box 12
- ✓ Blade, for #297

T1388	56.00	50.91
T1389	550.00	500.00
L1018	42.00	38.18

E2525 & E2526



MITRE BOXES - AUSTRIAN MADE - STUBAI

- ✓ Box, Mitre, #345601
- ✓ Box, Mitre, and Backsaw, #345701

E2525	11.95	10.86
E2526	18.95	17.23

T1581



T1388



MARPLES - BRITISH MADE

British made Marples layout tools are Sheffield made and available in a range of affordable high quality tools made from beech and plantation rosewood.

Beech Squares



Rosewood Squares



Rosewood Mitre Squares



SQUARES - TRY

- ✓ Beech Stock, 150mm, #200
- ✓ Beech Stock, 225mm, #201
- ✓ Beech Stock, 300mm, #202
- ✓ Rosewood Stock, with Brass Diamonds, 150mm, #19A
- ✓ Rosewood Stock, with Brass Diamonds, 225mm, #19B
- ✓ Rosewood Stock, with Brass Diamonds, 300mm, #19C

T7435	18.38	16.70
T7436	21.88	19.89
T7437	24.21	22.01
T7439	38.00	34.55
T7440	45.75	41.59
T7441	57.50	52.27

Try / Mitre Square



T7448

SQUARES - MITRE

- ✓ Mitre, Rosewood, with Brass Diamonds, 250mm, #19M
- ✓ Mitre, Rosewood, with Brass Diamonds, 380mm, #19P

T7443	50.25	45.68
T7444	57.00	51.82



SQUARES - TRY & MITRE

- ✓ Rosewood Stock, with Brass Diamonds, 250mm, #19T

T7446	45.25	41.14
-------	-------	-------

GAUGES - MARKING

- ✓ Beech, Half Round Head, Wood Face, Plastic Screw, #1
- ✓ Beech, Half Round Head, Brass Face, Plastic Screw, #2
- ✓ Rosewood, Half Round Head, Brass Face & Screw, #6

T7448	10.21	9.28
T7449	15.00	13.64
T7455	18.75	17.05



T7455

GAUGES - MORTICE & MARKING - SLIDE ACTION

- ✓ Beech, Square Head, Wood Face, Plastic Screw, #7
- ✓ Beech, Square Head, Brass Face, Plastic Screw, #8
- ✓ Rosewood, Square Head, Brass Face & Screw, #10C

T7457	18.54	16.86
T7458	25.21	22.92
T7460	50.00	45.45



T7457

GAUGES - MORTICE & MARKING - SCREW ACTION

- ✓ Rosewood, Square Head, Brass Face & Screw, #13C

T7461	83.25	75.68
-------	-------	-------

GAUGES - CUTTING

- ✓ Beech, Brass Face, Plastic Thumb Screw, #4
- ✓ Rosewood, Brass Face, Brass Thumb Screw, #6a

T7465	20.21	18.37
T7469	39.25	35.68

SPARE THUMB SCREW

- ✓ Screw, Thumb, for Marking Gauge

S0390	2.95	2.68
-------	------	------

BEVELS - MARPLES

- ✓ Wing Nut Lock, Beech, 190mm, #210
- ✓ Wing Nut Lock, Beech, 225mm, #211
- ✓ Wing Nut Lock, Beech, 267mm, #212
- ✓ Screwdriver Lock, Rosewood, 190mm, #20A
- ✓ Screwdriver Lock, Rosewood, 267mm, #20C
- ✓ Thumb Wheel Lock, Rosewood, 190mm, #20D
- ✓ Thumb Wheel Lock, Rosewood, 225mm, #20E
- ✓ Thumb Wheel Lock, Rosewood, 300mm, #20H

T7473	11.67	10.61
T7474	12.17	11.06
T7475	12.00	10.91
T7476	30.00	27.27
T7478	35.00	31.82
T7479	28.75	26.14
T7480	33.25	30.23
T7482	46.25	42.05



T7460

AWLS - MARPLES

- ✓ Awl, Beech, Round Blade, Screwdriver Point, 50mm blade,
- ✓ Awl, Beech, Reaming, Ground Square Blade, 50mm blade,

T7026	8.95	8.14
T7027	14.95	13.59



T7473

MARKING KNIVES - MARPLES

- ✓ Knife, Marking, Right Hand, Beech, #125
- ✓ Knife, Marking, Right Hand, Rosewood, #25

T7324	8.95	8.14
T7325	9.95	9.05



MALLETS - MARPLES

- ✓ Mallet, Carpenter's, Beech, 114mm, #30a

T3381	28.95	26.32
-------	-------	-------

PINCERS - AUSTRIAN MADE

- ✓ Polished Head, PVC Coated handles, 160mm

T7994	25.53	23.21
-------	-------	-------



T7026

BRAD PUSHER

Allows safe starting of panel pins in hard wood and full driving in soft woods.
Magnetic spring loaded, British made by Crown Tools

- ✓ Pusher, Brad, Rosewood handle #110XW

T3464	24.95	22.68
-------	-------	-------

Brad Pusher



T7324 & T7325



Pincers



S0390



**CHISELS - AUSTRIAN MADE - STUBAI
BEVEL EDGE**

Quality Austrian made bench chisels with tough poly propylene handles.

Note: There are 7 styles of bevel edge Stubai chisels available - contact us for other options.



Stubai Series 3543

		ITEM	RRP	Ex GST
✓	Set of 6, 6,10,14,18,22,26mm, Stubai, #354406	T9468	129.95	118.14
✓	2mm, #354302	T9449	26.95	24.50
✓	4mm, #354304	T9450	21.83	19.85
✓	6mm, (6), #354306	T9451	21.83	19.85
✓	8mm, #354308	T9452	21.83	19.85
✓	10mm, (6), #354310	T9453	21.83	19.85
✓	12mm, (4), #354312	T9454	21.83	19.85
✓	14mm, (6), #354314	T9455	21.83	19.85
✓	16mm, (4), #3543 16	T9456	22.61	20.55
✓	18mm, (6), #354318	T9457	23.60	21.45
✓	20mm, (4), #354320	T9458	24.01	21.83
✓	22mm, (6), #354322	T9459	24.95	22.68
✓	24mm, (4), #354324	T9460	24.95	22.68
✓	25mm, (4), #354325	T9461	24.95	22.68
✓	26mm, (6), #354326	T9462	24.95	22.68
✓	28mm, #354328	T9463	25.47	23.15
✓	30mm, #354330	T9464	25.47	23.15
✓	32mm, #354332	T9465	25.99	23.63
✓	35mm, #354335	T9466	27.14	24.67
✓	40mm, #354340	T9467	29.73	27.02

FIRMER - GERMAN MADE - KIRSCHEN

Kirschen Two Cherries Series 1021 - rectangular section, non bevel edge.

✓	Chisel, Firmer, Flat Hornbeam Handle, 6mm, #1021	T8589	33.93	30.85
✓	Chisel, Firmer, Flat Hornbeam Handle, 10mm, #1021	T8591	34.95	31.77
✓	Chisel, Firmer, Flat Hornbeam Handle, 12mm, #1021	T8592	35.60	32.36
✓	Chisel, Firmer, Flat Hornbeam Handle, 16mm, #1021	T8594	34.95	31.77
✓	Chisel, Firmer, Flat Hornbeam Handle, 20mm, #1021	T8596	41.15	37.41
✓	Chisel, Firmer, Flat Hornbeam Handle, 26mm, #1021	T8599	48.12	43.75



HAND PLANES

See below a range of hand planes which represent remarkable quality for the price. Japanese made and with close to the finish and build quality found in the market leading Canadian and American brands.

Pocket Block Planes with Fixed Mouth, 32mm Wide Blades - 135mm Overall

✓	Low 12 deg. Angle, 440grams	T2926	103.18	93.80
✓	Standard 20 deg. Angle, 440grams	T2927	103.18	93.80



Block Planes - Bevel Up - 160mm Overall

✓ Rebate, Low 12 deg. Angle, Fixed Mouth, 45 x 3mm blade	T2920	134.40	122.18
✓ Standard 20 deg. Angle, Adjustable Mouth, 35 x 3mm blade	T2921	122.61	111.47
✓ Low 12 deg. Angle, Adjustable Mouth, 35 x 3mm blade	T2922	122.61	111.47
✓ Rebate, Low 12 deg. Angle, Adj. Mouth, 44x3mm blade	T2923	150.73	137.03

Item: T2920



Item: T2921



Item: T2922



Item: T2923



Bench Planes - Bedrock Design - Bevel Down

✓ Smoothing, #4	T2937	152.14	138.31
✓ Jack, #5	T2938	179.02	162.75
✓ Fore, #6	T2939	214.86	195.33
✓ Jointer, #7	T2936	295.68	268.80

Full Specifications

- #4 Size, Bedrock Design, 51 x 3.0mm blade, 250 overall, 2250 grams
- #5 Size, Bedrock Design, Adjustable Mouth, 51 x 3.0mm blade, 355 overall, 2770 grams
- #6 Size, Bedrock Design, Adjustable Mouth, 60 x 3.0mm blade, 450 overall, 3730 grams
- #7 Size, Bedrock Design, Adjustable Mouth, 60 x 3.0mm blade, 560 overall, 4000 grams

Smoothing, #4



Jack, #5



Fore, #6



Jointer, #7



SAFETY CHUCK - QUICK CHANGE KEYLESS CHUCKS AND DRILLS - MADE IN USA

Safety chucks can be installed in any standard keyed Jacobs chuck in either stationery drill press or hand held drills. Once fitted the use of dangerous chuck keys is eliminated and drills and countersinks and any detent shank tooling can be quickly snapped into and out of the chuck.

CHUCKS

- ✓ Chuck, Quick Change, #40011

T0850	32.06	29.15
--------------	--------------	--------------

CHUCK EXTENSIONS - HEX DETENT SHANK

Used where a longer reach is required. Can be ganged together and accept tooling.

- ✓ Quick Chuck, with 3 inch Extension, #40013
- ✓ Quick Chuck, with 6 inch Extension, #40016

T0860	28.60	26.00
T0861	31.90	29.00

T0850



DRILLS - HSS - HEX DETENT SHANK

These are intergrally formed and can be sharpened but the bits are not replaceable.

✓ Set, 7 Piece, 1/16,3/32,1/8,5/32,3/16,7/32,1/4 inch	T0646	50.16	45.60
✓ Set, 13 Piece, 1/16 to 1/4 inch in 64ths	T0647	94.24	85.67
✓ 1/16 inch, (4/64 - 1.59mm)	T0648	6.08	5.53
✓ 5/64 inch, (5/64 - 1.98mm)	T0649	6.08	5.53
✓ 3/32 inch, (6/64 - 2.38mm)	T0650	6.54	5.94
✓ 7/64 inch, (7/64 - 2.78mm)	T0651	6.54	5.94
✓ 1/8 inch, (8/64 - 3.18mm)	T0652	6.54	5.94
✓ 9/64 inch, (9/64 - 3.57mm)	T0653	6.69	6.08
✓ 5/32 inch, (10/64 - 3.97mm)	T0654	6.84	6.22
✓ 11/64 inch, (11/64 - 4.37mm)	T0655	6.84	6.22
✓ 3/16 inch, (12/64 - 4.76mm)	T0656	7.90	7.19
✓ 13/64 inch, (13/64 - 5.16mm)	T0657	6.84	6.22
✓ 7/32 inch, (14/64 - 5.56mm)	T0658	9.88	8.98
✓ 15/64 inch, (15/64 - 5.95mm)	T0659	6.84	6.22
✓ 1/4 inch, (16/64 - 6.35mm)	T0660	12.16	11.05

T0860 & T0861



T0648~T0660



ADAPTER DRILLS - HEX DETENT SHANK

These allow drills to be replaced when broken or dull.

✓ 1/16 inch = 4/64 inch, (1.59mm), #42004	T0870	14.30	13.00
✓ 5/64 inch = 5/64 inch, (1.98mm), #42005	T0871	14.30	13.00
✓ 3/32 inch = 6/64 inch, (2.37mm), #42006	T0872	14.30	13.00
✓ 7/64 inch = 7/64 inch,, (2.78mm), #42007	T0873	14.30	13.00
✓ 1/8 inch = 8/64 inch, (3.18mm), #42008	T0874	14.30	13.00
✓ 9/64 inch = 9/64 inch, (3.57mm), #42009	T0875	13.20	12.00
✓ 5/32 inch = 10/64 inch, (3.97mm), #42010	T0876	14.30	13.00
✓ 11/64 inch = 11/64 inch, (4.37mm), #42011	T0877	14.30	13.00
✓ 3/16 inch = 12/64 inch, (4.76mm), #42012	T0878	14.30	13.00
✓ 13/64 inch = 13/64 inch, (5.16mm), #42013	T0879	14.30	13.00
✓ 7/32 inch = 14/64 inch, (5.56mm), #42014	T0880	14.30	13.00
✓ 15/64 inch = 15/64 inch, (5.95mm), #42015	T0881	14.30	13.00
✓ 1/4 inch = 16/64 inch, (6.35mm), #42016	T0882	14.30	13.00
✓ 9/32 inch = 18/64 inch, (7.14mm), #42018	T0883	17.60	16.00
✓ 5/16 inch = 20/64 inch, (7.94mm), #42020	T0884	17.60	16.00
✓ 3/8 inch = 24/64 inch, (9.53mm), #42024	T0885	20.35	18.50
✓ 1/8 inch = 8/64 inch, (3.18mm), #42008B, pkt 10	T0886	55.00	50.00
✓ Adapter, for Drills, 7 piece set, 1/16 to 1/4 inch, #40020	T0887	94.60	86.00

T0870~T0887



COUNTERSINK/COUNTERBORE - HEX DETENT SHANK - WITH HSS DRILLS

These cuts countersinks and, with an appropriate depth stop collar, plugable counterbores.

✓ Tool Steel, 5/64 = 5/64, (1.98mm)	T0910	22.00	20.00
✓ Tool Steel, 3/32 = 6/64 inch, (2.37mm)	T0911	22.00	20.00
✓ Tool Steel, 7/64 = 7/64 inch, (2.78mm)	T0912	22.00	20.00
✓ Tool Steel, 1/8 = 8/64 inch, (3.18mm)	T0913	22.00	20.00
✓ Tool Steel, 9/64 = 9/64 inch, (3.57mm)	T0914	22.00	20.00
✓ Tool Steel, 5 pce set, 5/64,3/32,7/64,1/8,9/64s	T0915	88.00	80.00
✓ TCT, 5/64 = 5/64, (1.98mm)	T0920	57.20	52.00
✓ TCT, 3/32 = 6/64 inch, (2.37mm)	T0921	57.20	52.00
✓ TCT, 7/64 = 7/64 inch, (2.78mm)	T0922	49.50	45.00
✓ TCT, 1/8 = 8/64 inch, (3.18mm)	T0923	49.50	45.00
✓ TCT, 9/64 = 9/64 inch, (3.57mm)	T0924	49.50	45.00
✓ TCT, 3/16 = 12/64 inch, (4.76mm)	T0925	49.50	45.00

T0910~T0925



T0620 & T0621



COUNTERSINKS - HEX DETENT SHANK - TOOL STEEL

✓ 82 degree	T0620	34.96	31.78
✓ 100 degree	T0621	34.96	31.78

GUIDE DRILLS - HEX DETENT SHANK

✓ 5/64 inch (1.98mm), #45105	T0930	31.35	28.50
✓ 7/64 inch (2.78mm), #45107	T0931	31.35	28.50
✓ 9/64 inch (3.57mm), #45109	T0932	34.65	31.50
✓ 11/64 inch (4.37mm), #45111	T0933	62.70	57.00
✓ 13/64 inch (5.16mm), #45113	T0934	62.70	57.00
✓ 5 piece Set, 5/64,7/64,9/64,11/64,13/64 inch	T0935	188.10	171.00
✓ Drill, Spare for Guide Drill, 5/64 inch	T0945	9.00	8.18
✓ Drill, Spare for Guide Drill, 7/64 inch	T0946	9.00	8.18
✓ Drill, Spare for Guide Drill, 9/64 inch	T0947	9.00	8.18
✓ Drill, Spare for Guide Drill, 11/64 inch	T0948	17.00	15.45
✓ Drill, Spare for Guide Drill, 13/64 inch	T0949	17.00	15.45

T0930~T0949



STOP COLLARS - DEPTH STOP

- ✓ 3/8 inch, for countersinks to 1/8 inch
- ✓ 1/2 inch, for 9/64 inch countersink

T0960	9.90	9.00
T0961	9.90	9.00

PLUG CUTTERS - HEX DETENT SHANK

- ✓ Cutter, Plug, 1/4 inch (6.35mm)
- ✓ Cutter, Plug, 3/8 inch, (9.53mm)
- ✓ Cutter, Plug, 1/2 inch, (12.7mm)
- ✓ Cutter, Plug, 5/8 inch, (15.88mm)
- ✓ Cutter, Plug, 3/4 inch, (19.05mm)
- ✓ Cutter, Plug, 1 inch, (25.4mm)

T0965	31.35	28.50
T0966	37.95	34.50
T0967	44.00	40.00
T0968	50.60	46.00
T0969	72.60	66.00
T0970	93.50	85.00

T0960 & T0961



T0965~T0970



Cross Hole Countersinks - Australian Made

The sweetest cutting countersink we know of and high speed steel so also useful in metalwork.

- ✓ HSS, 82deg, 4 to 10mm, #CH82-10
- ✓ HSS, 82deg, 5 to 16mm, #CH82-16
- ✓ HSS, 82deg, 8 to 20mm, #CH82-20

T0116	27.72	25.20
T0118	40.92	37.20
T0119	58.08	52.80

T0116 - T0119



Woodworking Vices

- ✓ 175mm Standard Wood Working, #60241
- ✓ 200mm Standard Wood Working, #60242
- ✓ Plain Screw, Pivot Jaw, 175mm (7 inch), #63245
- ✓ Plain Screw, 7 inch (180mm), #52PD

E2113	253.37	230.33
E2114	272.84	248.04
E2129	286.88	260.80
E2120	226.42	205.84

E3113 & E2114



E2129



E2120



Tapered Plug Cutters, Brad Point Wood Drills & Universal Borers

Plug cutters cut plugs in either face or end grain, usually in matching wood, although they can be used for contrasting effect, which are often used to conceal screw heads. The use of a drill press and good work-piece clamping practice are essential when using plug cutters. Snug plug cutters are superior because they make a slightly tapered plug which fully closes the hole they are hammered into.

Matching brad point or spur lip drills offer smooth cut holes and, with careful wood selection, invisible plugging.

Universal borers offer a range of larger sized, smoothly cut holes for numerous project requirements. A drill press is essential.

- ✓ Cutter, Plug, Tapered, 6mm, #701860
- ✓ Cutter, Plug, Tapered, 8mm, #701861
- ✓ Cutter, Plug, Tapered, 10mm, #701862
- ✓ Cutter, Plug, Tapered, 12mm, #701863
- ✓ Cutter, Plug, Tapered, 16mm, #701864

T0170	16.12	14.65
T0171	16.88	15.35
T0172	17.14	15.58
T0173	17.55	15.95
T0174	17.99	16.35

T0170~T0174



Brad point drills are optimised for cutting smooth edge holes in wood. Universal borers are a superior alternative to forstner bits and excel at large diameter, smoothly cut, shallow holes.

DRILLS - NATIVE BRAD POINT - step shank

- ✓ Drill, Brad Point, Set of 4, 4,6,8,10mm, Stubai, #300640
- ✓ Drill, Brad Point, Set of 5, 4,5,6,8,10mm, Stubai, #300650
- ✓ Drill, Brad Point, Stubai, 3mm, #300600
- ✓ Drill, Brad Point, Stubai, 4mm, #300601
- ✓ Drill, Brad Point, Stubai, 5mm, #300602
- ✓ Drill, Brad Point, Stubai, 6mm, #300603
- ✓ Drill, Brad Point, Stubai, 7mm, #300604

T3528	15.15	13.78
T3529	17.65	16.05
T3530	3.12	2.83
T3531	3.27	2.97
T3532	3.46	3.15
T3533	3.65	3.32
T3534	3.77	3.43

T3528~T3549



✓ Drill, Brad Point, Stubai, 8mm, #300605	T3535	4.46	4.06
✓ Drill, Brad Point, Stubai, 9mm, #300606	T3536	4.38	3.99
✓ Drill, Brad Point, Stubai, 10mm, #300607	T3537	5.85	5.31
✓ Drill, Brad Point, Stubai, Stepped Shank, 11mm	T3538	13.50	12.27
✓ Drill, Brad Point, Stubai, Stepped Shank, 12mm	T3539	14.96	13.60
✓ Drill, Brad Point, Stubai, Stepped Shank, 13mm	T3540	19.12	17.38
✓ Drill, Brad Point, Stubai, Stepped Shank, 14mm	T3541	20.54	18.67
✓ Drill, Brad Point, Stubai, Stepped Shank, 15mm	T3542	22.12	20.10
✓ Drill, Brad Point, Stubai, Stepped Shank, 16mm	T3543	23.35	21.22
✓ Drill, Brad Point, Stubai, Stepped Shank, 18mm	T3544	28.69	26.08
✓ Drill, Brad Point, Stubai, Stepped Shank, 20mm	T3545	32.38	29.44
✓ Borer, Universal, 12mm, #308504	T0323	19.56	17.78
✓ Borer, Universal, 13mm, #308505	T0324	20.68	18.80
✓ Borer, Universal, 14mm, #308506	T0325	21.81	19.82
✓ Borer, Universal, 15mm, #308507	T0326	21.94	19.94
✓ Borer, Universal, 16mm, #308508	T0327	22.80	20.73
✓ Borer, Universal, 18mm, #308509	T0328	23.45	21.32
✓ Borer, Universal, 20mm, #308510	T0329	24.66	22.42
✓ Borer, Universal, 22mm, #308511	T0330	25.61	23.29
✓ Borer, Universal, 24mm, #308512	T0331	27.73	25.21
✓ Borer, Universal, 25mm, #308513	T0332	27.86	25.33
✓ Borer, Universal, 26mm, #308514	T0334	29.12	26.47
✓ Borer, Universal, 28mm, #308515	T0335	30.98	28.16
✓ Borer, Universal, 30mm, #308516	T0336	32.36	29.42
✓ Borer, Universal, 32mm, #308517	T0337	36.04	32.76
✓ Borer, Universal, 34mm, #308518	T0338	39.42	35.83
✓ Borer, Universal, 35mm, #308519	T0339	40.28	36.62
✓ Borer, Universal, 36mm, #308520	T0340	41.58	37.80
✓ Borer, Universal, 38mm, #308521	T0341	44.26	40.24
✓ Borer, Universal, 40mm, #308522	T0342	46.47	42.24
✓ Borer, Universal, 45mm, #308523	T0343	56.77	51.61
✓ Borer, Universal, 50mm, #308524	T0344	67.06	60.97

T0323~T0344



C9000



C9015



C9048



C9095



C9103



Repackaging, Measuring & Decanting Supplies

Our beakers, jugs and funnels are high quality Italian made lab ware
Why should the science guys have all the fun?. Pipettes and cylinders
for accurate measuring. Safe and secure materials handling.

Polyethelene Bottles

✓ 250ml, with Resealable Witches Cap, 5 pcs	C9000	18.18	16.53
✓ 500ml, with Resealable Witches Cap, 4 pcs	C9001	14.61	13.29
✓ 1 litre, with Resealable Witches Cap, 3 pcs	C9002	17.65	16.04

✓ 250ml, with Cap, 5 pcs	C9010	14.07	12.79
✓ 500ml, with Cap, 4 pcs	C9011	11.88	10.80
✓ 1 litre, with Cap, 3 pcs	C9012	14.91	13.55

PLastic Pots

✓ Jar, Cosmetic, 250ml with lid, 5 pcs	C9015	14.15	12.86
--	--------------	--------------	--------------

Polyethelene Plastic Jerry Cans - Dangerous Goods Rated

✓ Bottle, Polyethelene, 1 litre, with DG Cap, 3 pcs	C9048	15.36	13.96
---	--------------	--------------	--------------

Funnels

✓ General Purpose, High Density Polyethelne, 100mm	C9095	3.22	2.92
✓ General Purpose, High Density Polyethelene, 120mm	C9096	4.02	3.65
✓ General Purpose, High Density Polyethelene, 140mm	C9097	6.37	5.79
✓ General Purpose, High Density Polyethelene, 180mm	C9098	11.73	10.66
✓ General Purpose, High Density Polyethelene, 220mm	C9099	16.08	14.62
✓ General Purpose, High Density Polyethelene, 280mm	C9100	20.77	18.88

- ✓ Powder/Liquid, Large Mouth, Polypropylene, 100mm
- ✓ Powder/Liquid, Large Mouth, Polypropylene, 120mm
- ✓ Powder/Liquid, Large Mouth, Polypropylene, 150mm

Graduated Wide Neck Storage Bottles - Round

- ✓ Bottle, Graduated, Wide Neck, Round 50ml, #409
- ✓ Bottle, Graduated, Wide Neck, Round 100ml, #409
- ✓ Bottle, Graduated, Wide Neck, Round 250ml, #410
- ✓ Bottle, Graduated, Wide Neck, Round 500ml, #411
- ✓ Bottle, Graduated, Wide Neck, Round,1000ml, #412
- ✓ Bottle, Graduated, Wide Neck, Round, 2000ml, #413

Graduated Wide Neck Storage Bottles - Square

- ✓ Bottle, Graduated, Wide Neck, Square, 100ml, #610
- ✓ Bottle, Graduated, Wide Neck, Square, 250ml, #611
- ✓ Bottle, Graduated, Wide Neck, Square, 500ml, #612
- ✓ Bottle, Graduated, Wide Neck, Square, 1000ml, #613
- ✓ Bottle, Graduated, Wide Neck, Square, 2000ml, #614

Wash Bottles

- ✓ Wide Mouth, Polyethylene, 250 ml, 04 Blue, #1637
- ✓ Wide Mouth, Polyethylene, 250 ml, 06 Yellow, #1637
- ✓ Wide Mouth, Polyethylene, 250 ml, 10 Red, #1637

Beakers - Graduated

- ✓ Polypropylene, 50 ml, #1802
- ✓ Polypropylene, 100 ml, #1803
- ✓ Polypropylene, 250 ml, #1805
- ✓ Polypropylene, 500 ml, #1806
- ✓ Polypropylene, 1000 ml, #1808

- ✓ Polypropylene, Blue Graduations, 25 ml, #1821
- ✓ Polypropylene, Blue Graduations, 100 ml, #1823
- ✓ Polypropylene, Blue Graduations, 500 ml, #1825
- ✓ Polypropylene, Blue Graduations, 1000 ml, #1826
- ✓ Polypropylene, Blue Graduations, 3000 ml, #818

Jugs

- ✓ Measuring, Polypropylene, Tall Profile, 250 ml
- ✓ Measuring, Polypropylene, Tall Profile, 500 ml
- ✓ Measuring, Polypropylene, Tall Profile, 1000 ml
- ✓ Measuring, Polypropylene, Tall Profile, 2000 ml
- ✓ Measuring, Polypropylene, Tall Profile, 3000 ml
- ✓ Pipette, Dropping, Bellows Type, 1.5ml, 10 pieces
- ✓ Pipette, Dropping, Bellows Type, 5.0ml, 10 pieces

- ✓ Rod, Stirring, Polypropylene, 244mm, 10 pcs

Measuring Cylinders

- ✓ Capacity 10ml, Grads. at 2ml, 13.5mm x 140mm
- ✓ Capacity 25ml, Grads. at 5ml, 18.0mm x 195mm
- ✓ Capacity 50ml, Grads. at 10ml, 25.5mm x 199mm
- ✓ Capacity 100ml, Grads. at 10ml, 30.5mm x 249mm
- ✓ Capacity 500ml, Grads. at 50ml, 55.0mm x 361mm
- ✓ Capacity 1000ml, Grads. at 100ml, 66.0mm x 439mm

Drum Tap

- ✓ Tap, for threaded Drums, 3/4 inch BSP, #375
Tap handle adjusts to vertical when tap fully screwed in.

C9103	8.04	7.31
C9104	8.71	7.92
C9105	11.39	10.35

C9121	3.36	3.05
C9122	3.78	3.44
C9123	4.50	4.09
C9124	4.95	4.50
C9125	6.60	6.00
C9126	13.20	12.00

C9132	4.14	3.76
C9133	4.65	4.23
C9134	5.70	5.18
C9135	6.90	6.27
C9136	12.60	11.45

C9152	6.95	6.32
C9153	6.95	6.32
C9154	6.95	6.32

C9161	4.46	4.05
C9162	5.28	4.80
C9163	5.85	5.32
C9164	9.00	8.18
C9165	15.75	14.32

C9167	4.29	3.90
C9168	5.45	4.95
C9169	9.75	8.86
C9170	18.00	16.36
C9171	43.50	39.55

C9180	15.66	14.24
C9181	17.50	15.91
C9182	20.10	18.27
C9183	46.90	42.64
C9184	49.58	45.07

C9214	7.95	7.23
C9215	8.15	7.41

C9220	19.80	18.00
-------	-------	-------

C9225	7.80	7.09
C9226	9.00	8.18
C9227	9.00	8.18
C9228	10.20	9.27
C9229	21.60	19.64
C9230	40.80	37.09

C9250	19.00	17.27
-------	-------	-------

C9121



C9132



C9152



C9167



C9225

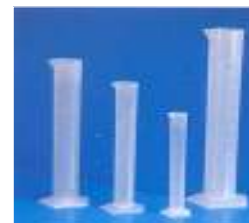

C9180

